

INTERMEDIATE (IPC) COURSE

PRACTICE MANUAL

PAPER: 7A

INFORMATION TECHNOLOGY



BOARD OF STUDIES
THE INSTITUTE OF CHARTERED ACCOUNTANTS OF INDIA

This practice manual has been prepared by the faculty of the Board of Studies. The objective of the practice manual is to provide teaching material to the students to enable them to obtain knowledge and skills in the subject. In case students need any clarifications or have any suggestions to make for further improvement of the material contained herein, they may write to the Director of Studies.

All care has been taken to provide interpretations and discussions in a manner useful for the students. However, the practice manual has not been specifically discussed by the Council of the Institute or any of its Committees and the views expressed herein may not be taken to necessarily represent the views of the Council or any of its Committees.

Permission of the Institute is essential for reproduction of any portion of this material.

© THE INSTITUTE OF CHARTERED ACCOUNTANTS OF INDIA

All rights reserved. No part of this book may be reproduced, stored in retrieval system, or transmitted, in any form, or by any means, electronic, mechanical, photocopying, recording, or otherwise, without prior permission in writing from the publisher.

Revised Edition : June, 2017

Website : www.icai.org

E-mail : bosnoida@icai.in

Committee / Department : Board of Studies

ISBN No. :

Price : ₹

Published by : The Publication Department on behalf of The Institute of Chartered Accountants of India, ICAI Bhawan, Post Box No. 7100, Indraprastha Marg, New Delhi – 110 002

Printed by :

A WORD ABOUT PRACTICE MANUAL

The impact of Information Technology on several aspects of accounting profession and practice has been pronounced over the last three decades. The revolutionary developments of various IT tools and techniques have a far reaching impact on the organizations. The survival and the growth of a dynamic profession such as Chartered Accountancy depends to a large extent, on understanding fundamentals of Business Information Systems, Business Process Automation and Telecommunication and Networking to face the emerging challenges in this globalized competitive business environment.

Due to prompt world of Information and Communication Technologies, the Institute felt an urgent need to relook the syllabus of IT related papers separately and hence the syllabus of "Information Technology" was revised with a view to rationalize the same in the light of recent technological developments by making necessary modifications therein. The paper provides a conceptual knowledge of 'How Business Process Management and contemporary Information Systems are closely interfaced with IT to provide the required Business Process Automation for enterprises'. The knowledge acquired by the student through the study of the course entitled "Information Technology" will be very helpful in the current dynamic business scenario.

This Practice Manual has been designed with the need of home-study and distance-learning students in mind. Such students require full coverage of the syllabus topics, and also the facility to undertake extensive question practice. The main aim of this Practice Manual is to provide guidance as to the manner of writing an answer in the examination. The main features of this Practice Manual are as follows:

- **Concepts in Brief:** Important definitions, concepts and points have been given on each topic for quick recapitulation in accordance with the study material.
- **Questions:** Numerous questions are incorporated for practice questions. Students are expected to attempt the questions and then compare their answers with the answers provided in the manual to improve their presentation in the examination.
- **Assignment:** Exercises have been given at the end of each chapter for independent practice.

New questions have been incorporated in this edition vis-à-vis the revisions carried out in the study material and have been highlighted in **Bold** and *Italics*. This edition also contains the questions of the past examination. The matrix showing chapter-wise distribution of past examination questions with marks has been included on the next page. The matrix will assist the students in getting an idea about the trend of questions being asked and relative weightage of each topic in the past examination. It will serve as a useful and handy reference guide while preparing for the examination. It will guide the students to improve their performance in the examination and help them to work upon their grey areas.

In case you need any further clarification/guidance, please send your queries at bosnoida@icai.in / sukriti.arora@icai.in.

HAPPY READING AND BEST WISHES!

Paper – 7A: Information Technology

Statement indicating Chapter-wise distribution of Questions along with Marks for Past three Examinations

Chapter No.	Name of the Chapter	Terms of Examination						Total Marks (app)
		November 2015		May 2016		November 2016		
		Question	Marks	Question	Marks	Question	Marks	
1	Business Process Management & IT	1(a), 2, 7(b)	12	1(a), 2(a), 2(b), 7(a)	12	5, 6(a)	12	12
2	Information Systems and IT Fundamentals	1(b), 3(a), 3(b), 7(c)	12	1(b), 3(a), 3(b), 7(b)	12	1(e), 3(b), 6(b), 7(b), 7(c)	14	13
3	Telecommunication and Networks	1(c), 1(d), 4(a), 4(b), 7(a)	14	1(c), 4(a), 4(b), 7(c)	12	1(b), 1(d), 7(a), 7(d)	8	11
4	Business Information Systems	5(a), 5(b), 7(e)	10	1(d), 5(a), 5(b), 7(d)	12	1(c), 2(b), 3(a), 4(a), 7(e)	16	13
5	Business Automation through Application Software	1(e), 6(a) 6(b), 7(d)	12	1(e), 6(a), 6(b), 7(e)	12	1(a), 2(a), 4(b)	10	11

Note: Question paper of the aforementioned examination can be accessed from the 'BoS Knowledge Portal' under the section 'Students' on the Institute's website www.icai.org.

CONTENTS

INFORMATION TECHNOLOGY

CHAPTER – 1	Business Process Management & IT	1.1 – 1.33
CHAPTER – 2	Information Systems and IT Fundamentals	2.1 – 2.26
CHAPTER – 3	Telecommunication and Networks	3.1 – 3.39
CHAPTER – 4	Business Information Systems	4.1 – 4.25
CHAPTER – 5	Business Process Automation through Application Software	5.1 – 5.17

1

Business Process Management & IT

1.1 Introduction

Business processes are pervasive in any organization and represent all activities that an organization undertakes. Business Process Management evaluates the efficacy and usefulness of business processes for reducing costs and ensures value creation. This chapter provides key concepts, terms, methodologies, techniques and life cycle of Business Process Management.

1.2 Overview of Business Processes

The key concept of Business Process Management (BPM) is the convergence of technologies with process management theories.

1.2.1 What is a Process?

From a business perspective, a **Process** is a coordinated and standardized flow of activities performed by people or machines, which can traverse functional or departmental boundaries to achieve a business objective and creates value for internal or external customers.

1.2.2 What is a Business Process?

A **Business Process** consists of a set of activities that are performed in coordination in an organizational and technical environment. These activities jointly realize a business goal. Each business process is enacted by a single organization, but it may interact with business processes performed by other organizations.

Process Management is based on a view of an organization as a system of interlinked processes, which involves concerted efforts to map, improve and adhere to organizational processes. It is the ensemble of activities of planning and monitoring the performance of a process.

1.2.3 Business Process flow

Examples of key business processes life cycle pertaining to accounting, sales and purchase are explained below:

1.2 Information Technology

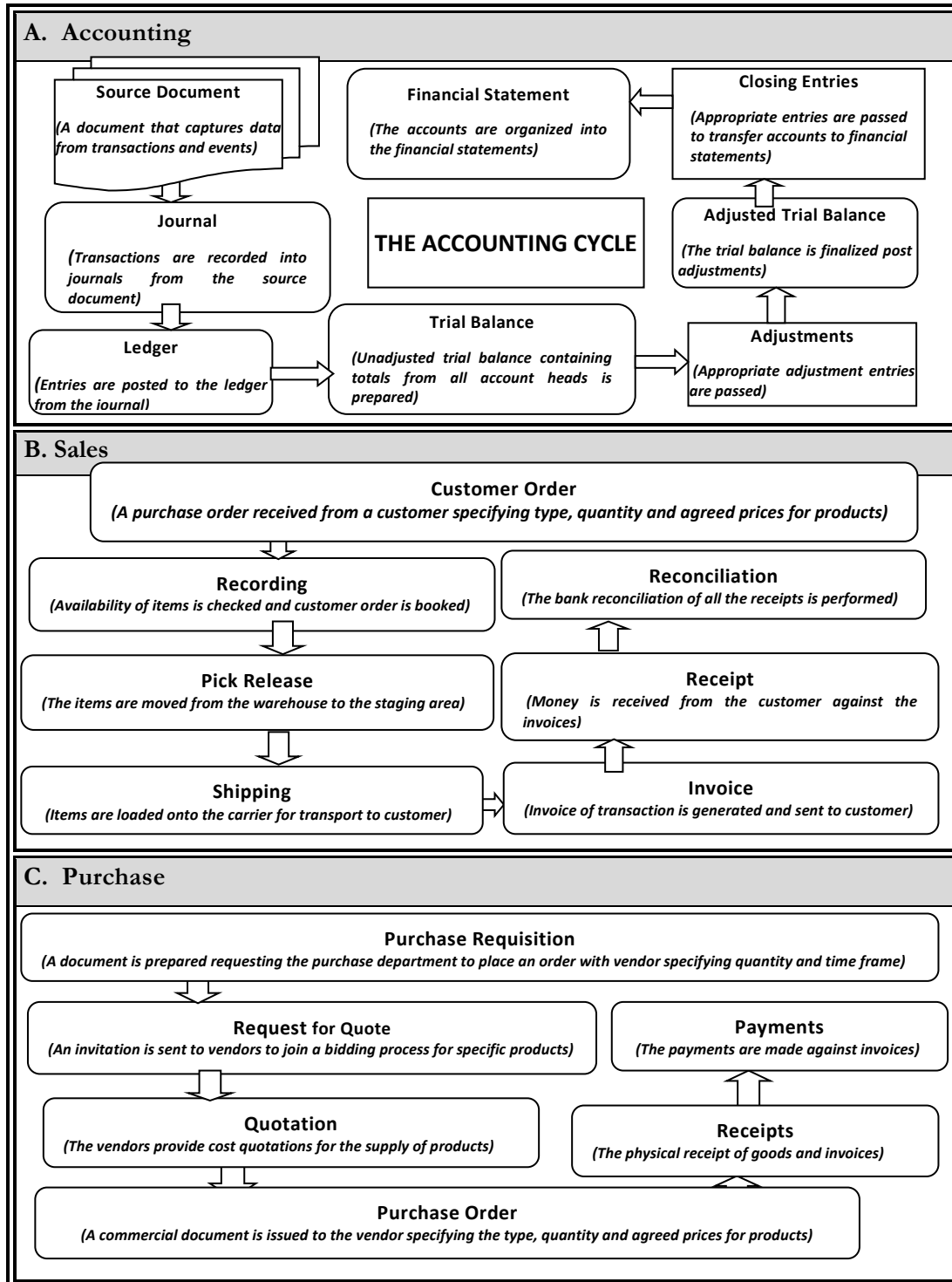

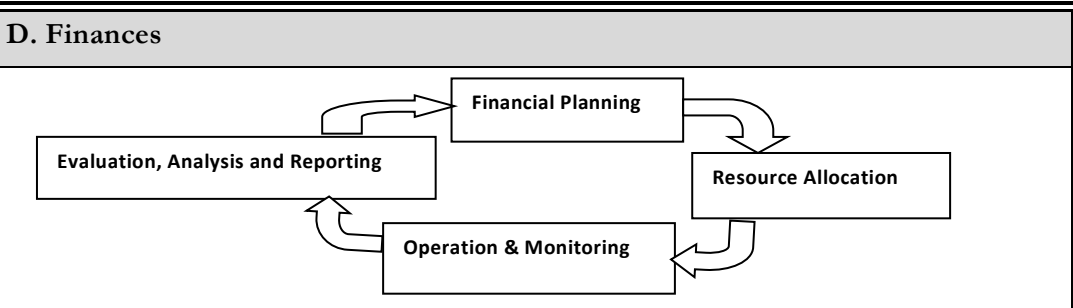

1.3 Classification of Business Processes

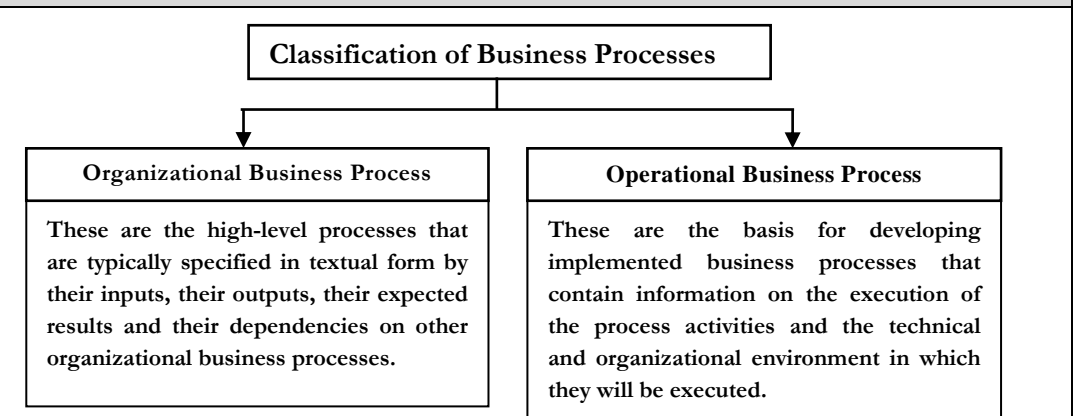

1.4 Business Process Management (BPM)

Business Process Management (BPM) is defined as the achievement of an organization’s objectives through the improvement, management and control of essential business processes. It refers to the closed loop, iterative management of business processes over their complete life cycle.

1.4.1 Business Process Management Principles and Practices

<p>PRINCIPLES</p> <ul style="list-style-type: none"> • Processes are Assets • Value to Customers • Continuous improvement of processes 	<p>PRACTICES</p> <ul style="list-style-type: none"> • Process-oriented organizational structure • Appoint Process Owners • Top-Down Commitment, bottom up execution • Use Information Technology to Manage Processes • Collaborate with Business Partners • Continuous Learning and Process Improvement • Align Employee Rewards to Process Performance • Utilize BPR, TQM and other process improvement tools
--	---

1.4 Information Technology

1.4.2 Business Process Management Life Cycle

This has five phases – **Analysis, Design, Implementation, Run & Monitor, and Optimize** phase.

1.5 Theories of Process Management

BPM is a combination of systems, methods and tools for ensuring processes that are improved on a continuous basis to achieve enterprise objectives. Under the BPM framework, Business Process Re-engineering (BPR) and incremental process improvement methodologies (i.e., Six Sigma, TQM, etc.) are tools that organizations can use to implement process improvement.

1.5.1 Six Sigma

It follows a life-cycle having phases: **Define, Measure, Analyze, Improve and Control (or DMAIC)**.

1.5.2 Total Quality Management (TQM)

TQM is based on quality management from the customer's point of view. TQM processes are divided into four sequential categories: Plan, Do, Check, and Act (the PDCA cycle).

(i) Plan: In the planning phase, people define the problem to be addressed, collect relevant data, and ascertain the problem's root cause;

(ii) Do: In the doing phase, people develop and implement a solution, and decide upon a measurement to gauge its effectiveness;

(iii) Check: In the checking phase, people confirm the results through before-and-after data comparison;

(iv) Act: In the acting phase, people document their results; inform others about process changes, and make recommendations for the problem to be addressed in the next PDCA cycle.

1.5.3 Business Process Reengineering (BPR)

Business Process Reengineering (BPR) is the fundamental rethinking and radical redesign of processes to achieve dramatic improvement, in critical, contemporary measures of performance such as cost, quality, service and speed. BPR aims at major transformation of the business processes to achieve dramatic improvement. The success factors of BPR are: Organization wide commitment, BPR Team composition, Business need analysis, Adequate IT infrastructure, effective change management, and ongoing continuous improvement.

1.6 BPM Implementation

BPM implementation can make an organization process – centric.

1.6.1 Key factors to consider in implementing BPM	
Factors	Key Considerations
Scope	A single process, a department, the entire company
Goals	Process understanding, Process Improvement, Process Automation/Optimization and Process re-engineering
Methods to be used	Six Sigma, BPM Life Cycle Method, TQM, Informal methods
Skills Required	Consultants, Train Employees, Formal Certification, Basic Education, Existing Skill sets
Tools to be used	White-Boards, Sticky Notes, Software for Mapping, Documenting, Software for Simulation, Comprehensive BPMS
Investments to Make	Training, Tools, Time
Sponsorship/Buy-in Needed	Executive Level, Department Level, Process Owner Level, Employee Level
1.6.2 Need for a BPM implementation	
<p>The volume of work and the complexity of the business process demand that organizations look for possible IT applications to support and automate their processes. Business Process Management is a prerequisite for organizational competitiveness. It includes establishing and maintaining an environment in which people working together perform a specific job efficiently. For example – The marketing department has its Enterprise Content Management (ECM) system used to inform the consumer of the organization’s products or services; the sales department has a Customer Relation Management (CRM) system to allow the company to up- and cross-sell; and the delivery department has an Enterprise Resource Planning (ERP) system to process the order and send an invoice.</p>	
1.6.3 Automation of the functional units	
<p>Consumer is becoming more and more demanding with respect to delivery time – where customers used to expect and accept days or weeks for delivery, same time, the consumer is demanding higher quality of the products or services. Finally, the product or service is becoming more and more personalized (and thus more complex), supported by increased customer services.</p>	
1.6.4 Challenges in implementing BPA	
<p>Organizations rely on a complex, interrelated information systems infrastructure to effectively thrive in the ever-increasing, competitive digital world. The product, service, price, competition etc. have increased the complexity of the business.</p>	

1.6 Information Technology

1.6.5 BPM Technology

BPM technology can complement existing (and future) investments in applications and give organizations the ability to implement a real – time process improvement without the extensive process conversion efforts as the original business processes already exist. To achieve these benefits, Business Process Layer is introduced in the Traditional IT architecture. The traditional IT architecture contains three layers: Database, Application and Presentation.

1.6.6 Value Chain Automation

Value chain is defined as a chain of activities that a firm operating in a specific industry performs in order to deliver a valuable product or service for the market. Research and development; Design of products, services, or processes; Production; Marketing and sales; Distribution and Customer service are some of the business functions of the value chain.

1.6.7 Business Process Automation (BPA): Benefits & Risks

Saving on costs, staying ahead in competition and fast service to customers are some of the benefits along with risk to jobs and false sense of security as risks.

1.7 Accounting Systems Automation

Accounting Information System (AIS) is defined as a computer based system of collection, storage and processing of financial and accounting data that is used by decision makers. An important function of AIS is to efficiently and effectively collect and process the data about a company's transactions.

1.7.1 Basic functions of an Accounting Information System (AIS)

- **Collect and store data** - Source documents such as sales order, sales invoice, order processing, purchase order etc. are used to capture transaction data.
- **Record Transaction** - Transactions data are recorded into journals that provide management with information useful for decision making.
- **Safeguard Organizational Assets** - Provide adequate controls to ensure that data is recorded and processed accurately by safeguarding organizational assets (data and systems) by providing adequate documentation of all business activities and an effective segregation of duties.

1.7.2 Processing Cycles of Accounts BPM

- (i) **Financing Cycle** – provides a clear view of firm's processing framework and involves activities of obtaining necessary funds to run the organization, repay creditors, and distribute profits to investors.
- (ii) **Revenue Cycle** - involves activities of selling goods or services and collecting payment for sales.

- (iii) **Expenditure Cycle** - involves activities of buying and paying for goods or services used by the organization.
- (iv) **Human Resource Cycle/Payroll Cycle** - involves activities of hiring and paying employees.
- (v) **Production Cycle** - involves the recurring set of business activities and related data processing operations associated with the manufacturers of products including activities like converting raw materials and labor into finished goods.

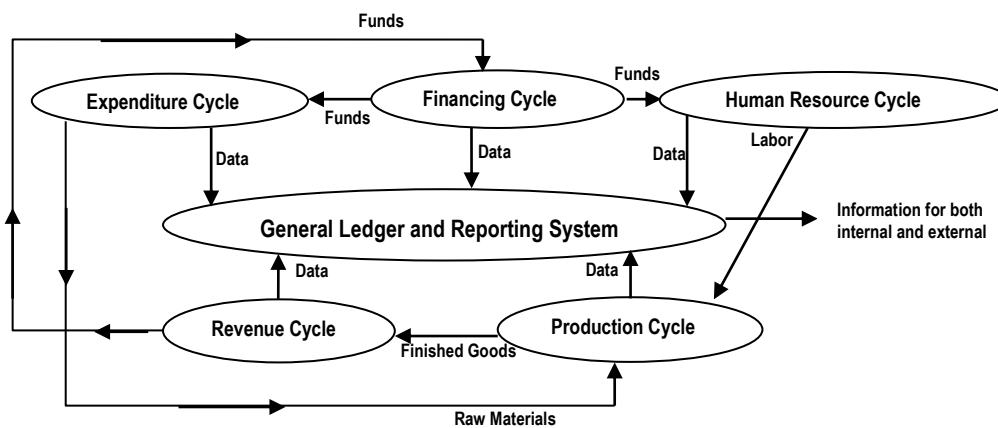

Accounting Information Systems and its Subsystems

General Ledger & Reporting System – This involves the information processing operations involved in updating the general ledger and preparing reports that summarize the results of an organization’s activities.

Data Processing Cycle - The Data Processing Cycle consists of following basic steps with alerts, controls and feedback at each step:

- **Data input** - Involves the activities like capturing the data, implementing control procedures, recording in journals, posting to ledgers and preparation of reports.
- **Data storage** - Involves organizing the data in master file or reference file of an automated system for easy and efficient access.
- **Data processing** - Involves addition, deletion and updating of the data in the transaction file, master file or reference file.
- **Information output** - Involves generation of documents and managerial reports in printable or electronic form for addressing queries, to control operational activities and help the management in decision making.

1.8 Impact of IT on BPM and Risks of failure of IT

BPM solutions that are process – centric integrate People, Systems and Data.

1.8.1 Benefits of BPMS

BPMS mainly automates repetitive business processes; monitors, extracts formats and distributes information to systems and people; optimizes processes; reduces the administrative activities involved in compliance and ISO activities and frees up employees’ time.

1.8.2 Business Risks of failure of IT

Superficial or deficient executive involvement; deficient project management; breakdown in gap analysis; limited options for customization of the BPM software; too complicated to be customized; failure to identify future business needs; inadequate assessment of the need for change management etc. are some of the major business risks of failure of IT.

1.8.3 Information as a Business Asset

Information becomes an asset for an organization if it is useful, digital, accessible, relevant, accurate, trust-worthy, searchable, understandable, spatially enabled and shareable at the time when required.

1.9 Approaches to Mapping System

Insufficient and deficient documentation costs organizations time, money and, therefore, documentation is as important as the product is. Some of the commonly used documentation methods are summarized below:







1.9.1 Entity Relationship Diagram

Entity-Relationship (E/R) Modeling is defined as a data modeling technique that creates a graphical representation of the entities, and the relationships between entities, within an Information System. ER diagrams repeatedly bring into play symbols to symbolize three dissimilar types of information.

- **Entity** is represented by Rectangle labeled with a singular noun and denotes a physical object, an event or a concept.
- **Relationship** is represented by Diamonds that denotes an association that exists between two entities.
- **Attributes** are represented by Ovals.

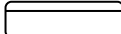
1.9.2 Data Flow Diagram

A Data Flow Diagram (DFD) illustrates technical or business processes with the help of the external data stored, the data flowing from a process to another, and the results. The four major DFD component's symbols are as follows:

Term	Symbols	Meaning
Entity		An entity is the source or destination of data; also referred to as agents, terminators, or source/sink.
Process	 or 	A process receives input and generates some output.
Data Store	 or 	A data store is where a process stores data between processes for later retrieval by that same process or another one. Files and tables are considered data stores.
Data Flow		Data flow is the movement of data between the entity, the process and the data store.

Any system in general is too complex to be shown on a single DFD. Decomposition is an iterative process of exploding DFDs to create more detail. Data Flow Diagrams can be expressed as a series of levels. We begin by making a list of business activities to determine the DFD elements (external entities, data flows, processes, and data stores). Context Diagram shows the interaction between the system and external agents.

- The Context Diagram is a high-level DFD that shows the entire system as a single process and shows the interaction between the system and external agents which act as data sources and data sinks and gives no clues as to its internal organization.
- The context-level DFD is next "exploded", to produce Level 1 DFDs for each process that shows how the system is divided into sub-systems (processes), each of which deals with one or more of the data flows to or from an external agent, and which together provide all of the functionality of the system as a whole.

1.9.3 Flowchart

A **Flowchart** is a diagram prepared by the programmer of the sequence of steps involved in solving a problem. It is an essential tool for programming and it illustrates the strategy and thread of logic followed in the program. Flowcharts may be divided into four categories and as such they may be likened to the geographical map about the extent of detail:

Type of Flowchart	Characteristics
System Outline Chart	Lists the inputs, files processed and outputs without regard to any sequence whatever.
System Flowchart	Presents an overview of the data flow through all parts of a data processing system.
Run Flowchart	Are prepared from the system flowcharts and show the reference of computer operations to be performed.
Program Flowchart	Most detailed and are concerned with the logical/arithmetic operations on data within the CPU and the flow of data between CPU on one hand and the input/output peripherals on the other.

1.9.4 Decision Tree

Also, termed as an **Inference or Logical tree**, it is a tree-like representation and is defined as a collection of a basis (condition) and a conclusion (action) and is a one way to display an algorithm. It is a decision support tool that uses a tree-like graph or model of decisions and their possible consequences, including chance event outcomes, resource costs, and utility.

1.9.5 Decision Table

A **Decision Table** is a table which may accompany a flowchart defining the possible contingencies that may be considered within the program and the appropriate course of action for each contingency. A Decision Table is divided into four quadrants – **Condition Stub, Condition Entries, Action Stub and Action Entries**.

1.10 Information Technology

Question 1

Define Business Process Re-engineering. Explain it with suitable example.

Answer

Business Process Reengineering (BPR) is defined as the fundamental rethinking and radical redesign of processes to achieve dramatic improvement, in critical, contemporary measures of performance such as cost, quality, service and speed. It involves changes in structures and in processes within the business environment. The entire technological, human, and organizational dimensions may be changed in BPR. Information Technology plays a major role in BPR as it provides office automation; allows the business to be conducted in different locations; and provides flexibility in manufacturing, permits quicker delivery to customers and supports rapid and paperless transactions. In general, it allows an efficient and effective change in the way work is performed. Business Process Re-engineering is also known as **Business Process Redesign, Business Transformation, or Business Process Change Management.**

An example of BPR application

If a bank customer enters the bank determined to apply for a loan, apply for an ATM card and open a savings account, most probably s/he must visit three different desks in order to be serviced. When BPR is applied to an organization, the customer communicates with only one person, called "case manager", for all three inquiries. Under BPR, while the loan application team processes the loan application, the case manager "triggers" the account team to open a savings account and the ATM team to supply the customer with an ATM card. The customer leaves the bank having a response for his loan application, a new savings account and an ATM card, and all these without having to move around the desks for signatures and documents. All the customer's requests were satisfied at the same time in parallel motion.

Question 2

Discuss the following:

- (a) Six Sigma
- (b) BPM Life Cycle

Or

Name the various phases of Business Process Management Life Cycle (BPM–L Cycle) in logically correct order.

- (c) Total Quality Management (TQM)

Or

Write short note on Total Quality Management.

Answer

- ◆ **Six Sigma** – Six Sigma employs quality management and statistical analysis of process outputs by identifying and removing the causes of defects (errors) and minimizing variability in manufacturing and business processes. Each Six Sigma project carried out

within an organization follows a defined sequence of steps and has quantified value targets, for example: reduce process cycle time, reduce pollution, reduce costs, increase customer satisfaction, and increase profits. It follows a life-cycle having phases: **Define, Measure, Analyze, Improve and Control (or DMAIC)** which are described as follows.

- (i) **Define:** Customers are identified and their requirements are gathered. Measurements that are critical to customer satisfaction [Critical to Quality, (CTQ)] are identified for further project improvement.
- (ii) **Measure:** Process output measures that are attributes of CTQs are determined and variables that affect these output measures are identified. Data on current process are gathered and current baseline performance for process output measures are established. Variances of output measures are graphed and process sigma are calculated.
- (iii) **Analyze:** Using statistical methods and graphical displays, possible causes of process output variations are identified. These possible causes are analyzed statistically to determine root cause of variation.
- (iv) **Improve:** Solution alternatives are generated to fix the root cause. The most appropriate solution is identified using solution prioritization matrix and validated using pilot testing. Cost and benefit analysis is performed to validate the financial benefit of the solution. Implementation plan is drafted and executed.
- (v) **Control:** Process is standardized and documented. Before and after analysis is performed on the new process to validate expected results, monitoring system is implemented to ensure process is performing as designed. Project is evaluated and lessons learned are shared with others.

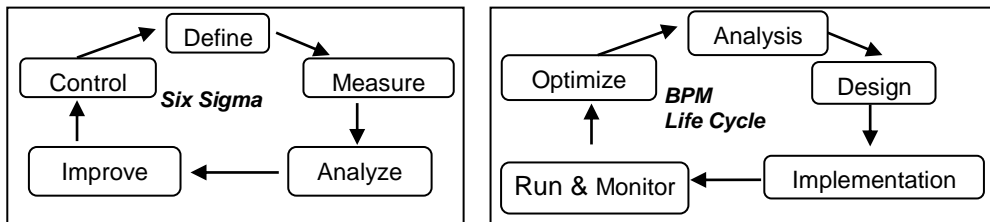

- ◆ **BPM Life Cycle (BPM-L)** - Business Process Management-Life cycle establishes a sustainable process management capability that empowers organizations to embrace and manage process changes successfully. Because it incorporates both human resources and technology—culture, roles and responsibilities, as well as data content, applications and infrastructure—the approach enables fully informed decision-making right across an organization. Phases are **Analysis, Design, Implementation, Run & Monitor and Optimize**.

- (i) **Analysis phase:** This involves analysis of the current environment and current processes, identification of needs and definition of requirements.
- (ii) **Design phase:** This involves evaluation of potential solutions to meet the identified needs, business process designing and business process modeling.

1.12 Information Technology

- (iii) **Implementation phase:** This involves project preparation, blue printing, realization, final preparation, go live and support.
- (iv) **Run and Monitor phase:** This involves business process execution or deployment and business process monitoring.
- (v) **Optimize:** Iterate for continuous improvement.
- ◆ **Total Quality Management (TQM)** is a management mechanism designed to improve a product or process by engaging every stakeholder and all members of an organization as well as the customers and aims at improving the quality of the products produced and the process utilized. TQM ultimately aims at complete customer satisfaction through ongoing improvements.

Question 3

Classify each of the following items as belonging in the revenue, expenditure, human resources/payroll, production, or financing cycle.

- (a) Purchase raw materials
- (b) Decide how many units to make next month
- (c) Pay for raw materials
- (d) Disburse payroll checks to factory workers
- (e) Hire a new assistant controller
- (f) Update the allowance for uncollectible accounts
- (g) Establish a ₹ 10,000 credit limit for customer XYZ Company

Answer

Note: Refer to Section 1.7.2 in summary for better understanding.

- (a) Expenditure Cycle
- (b) Production Cycle
- (c) Expenditure Cycle
- (d) Payroll Cycle
- (e) Payroll Cycle
- (f) Financial Reporting Cycle
- (g) Revenue Cycle

Question 4

Explain different types of relationships in Entity-Relationship Model with suitable examples.

Answer

Relationship: It is defined as an association between two or more entities.

Types of Relationships in E-R Model are as follows:

- (i) **One-to-One relationship (1:1)** - A One-to-One relationship is shown on the diagram by a line connecting the two entities.

Example: A Teacher may be in-charge of a class. Each class must be in-charge of by one teacher.

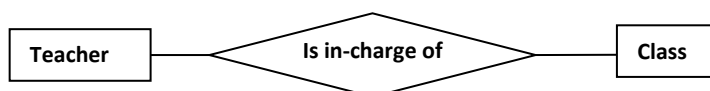

A student has one and only one Report card. Each report card is owned by one and only one student.

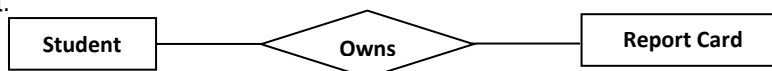

- (ii) **One-to-Many relationships (1:N)** – A One-to-Many relationship is shown on the diagram by a line connecting the two entities with a “crow's foot” symbol denoting the 'many' end of the relationship.

Example: A student may borrow some books from the library. A book in the library may be borrowed by at most a student.



A class is formed by a group of atleast one student. Each student is allocated to one and only one class.



- (iii) **Many-to-One relationships (M:1)** – It is the reverse of One-to-Many relationship.

Example: As in two or more parent records to a single child record. For example,



When three administrators in a small town report to one minister.



- (iv) **Many-to-Many relationships (M:N)** - A Many-to-Many relationship is shown on the diagram by a line connecting the two entities with 'crow's foot' symbols at both ends.

Example: A student enrolls in atleast one course. A course is enrolled by at least one student.



A student may apply for more than one scholarship. Each scholarship may receive some applications from student, or none.



Question 5

A university consists of a number of departments. Each department offers several courses. A number of modules make up each course. Students enroll in a particular course and take modules towards the completion of that course. Each module is taught by a lecturer from the appropriate department, and each lecturer tutors a group of students. Draw an E-R Diagram.

Answer

First, we will identify entities which are - Department, Course, Module, Student, Lecturer.

Further, following are the relationships:

- (a) Each department **offers** several courses;
- (b) A number of modules **make up** each course;
- (c) Students **enroll in** a particular course;
- (d) Students **take** modules;
- (e) Each module is **taught by** a lecturer;
- (f) A lecturer **from the** appropriate department; and
- (g) Each lecturer **tutors** a group of students.

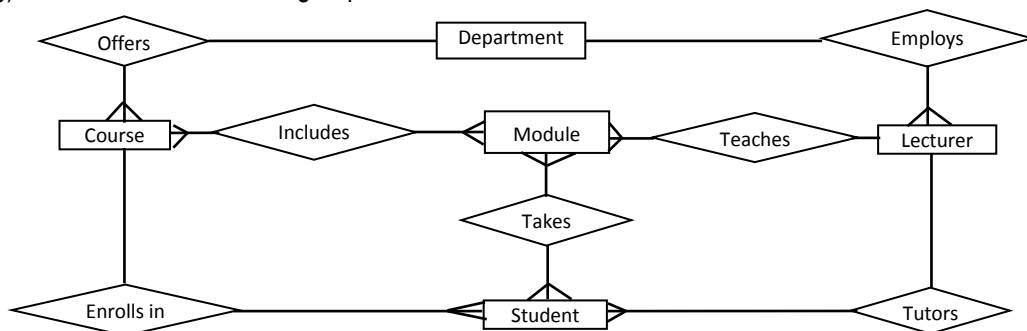

Question 6

Draw a Context Level Diagram for Payroll Processing System that interacts with the following five agents: Government Agencies; Employees; Management; Time Keeping and Human Resources.

Answer

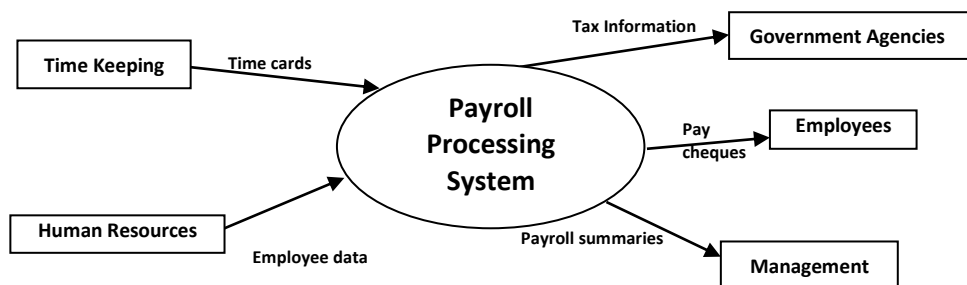

The DFD shown in the figure displays the inputs and outputs of the payroll processing application as well as the data sources and destinations external to the application. Thus this context diagram uses rectangles to identify Timekeeping and Human Resources as external entities, despite the fact that these departments are internal to the company. This is because those entities are external to the Payroll Processing System under study.

Question 7

Differentiate between Flowchart and Data Flow Diagram.

Answer

Flowchart	Data Flow Diagram (DFD)
Flow chart presents steps to complete a process.	Data Flow Diagram presents the flow of data.
Flow chart does not have any input from or output to an external source.	DFD describes the path of data from an external source to internal source or vice versa.
The timing and sequence of the process is aptly shown by a flowchart.	Whether processing of data is taking place in a particular order or several processes are taking place simultaneously is described by a DFD.
Flow chart shows how to make a system function.	DFD defines the functionality of a system.
Flow chart is used in designing a process.	DFD is used to describe the path of data that will complete the process.
Types of Flow charts – System, Data, Document and Program.	Types of DFD – Physical data flow and Logical data flow.

Question 8

A company has 2,500 employees. Their salaries are stored as J(s), 1, 2, 2500. The salaries are divided in four categories as under:

- (i) Less than ₹1,000
- (ii) ₹1,000 to ₹2,000
- (iii) ₹2,001 to ₹5,000
- (iv) Above ₹5,000.

Draw a flow chart for finding the percentage of the employees in each category.

Answer

The flow chart is as follows:

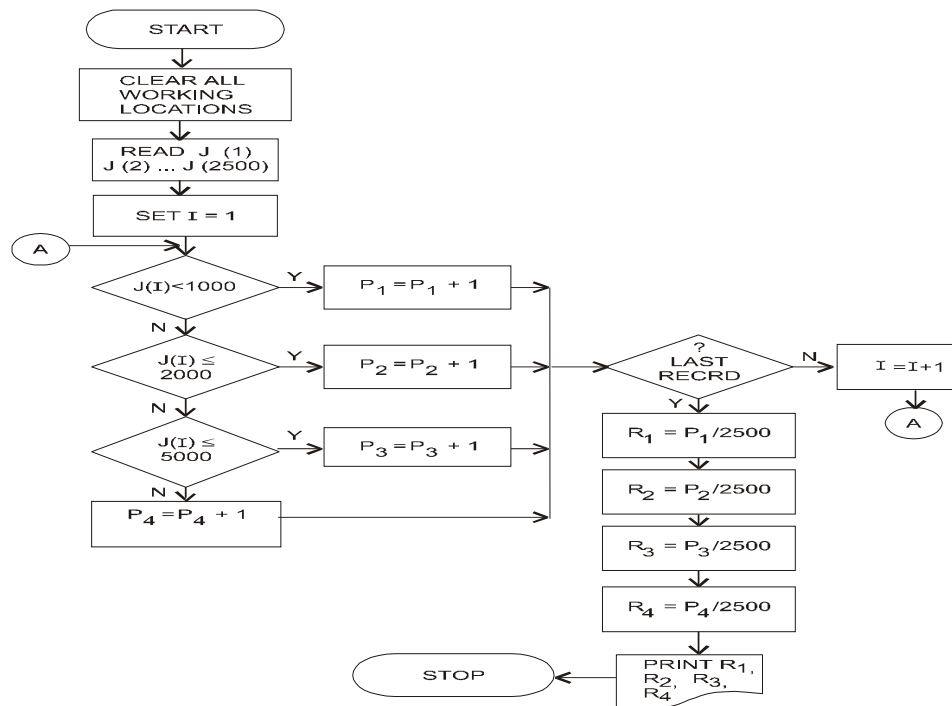

Question 9

A bicycle shop in Delhi hires bicycles by the day at different rates as shown in table: -

Season	Charges per day
Spring (March - May)	₹ 8.00
Summer (June - August)	₹ 9.50
Autumn (Sept - Nov.)	₹ 5.00
Winter (Dec. - Feb.)	₹ 6.00

To attract his customers, the proprietor also gives a discount on the number of days a bicycle is hired for. If the hire period is more than 10 days, a reduction of 15% is made. For every bicycle hired, a deposit of ₹ 20 must be paid. Develop a flowchart to print out the details for each customer such as name of customer, number of days a bicycle is hired for, hire-charges and total charges including the deposit. It is also assumed that there are 25 customers and complete details for each customer such as name of customer, season and number of days the bicycle is required for is inputted through console.

Answer

The required flowchart is shown in Fig.

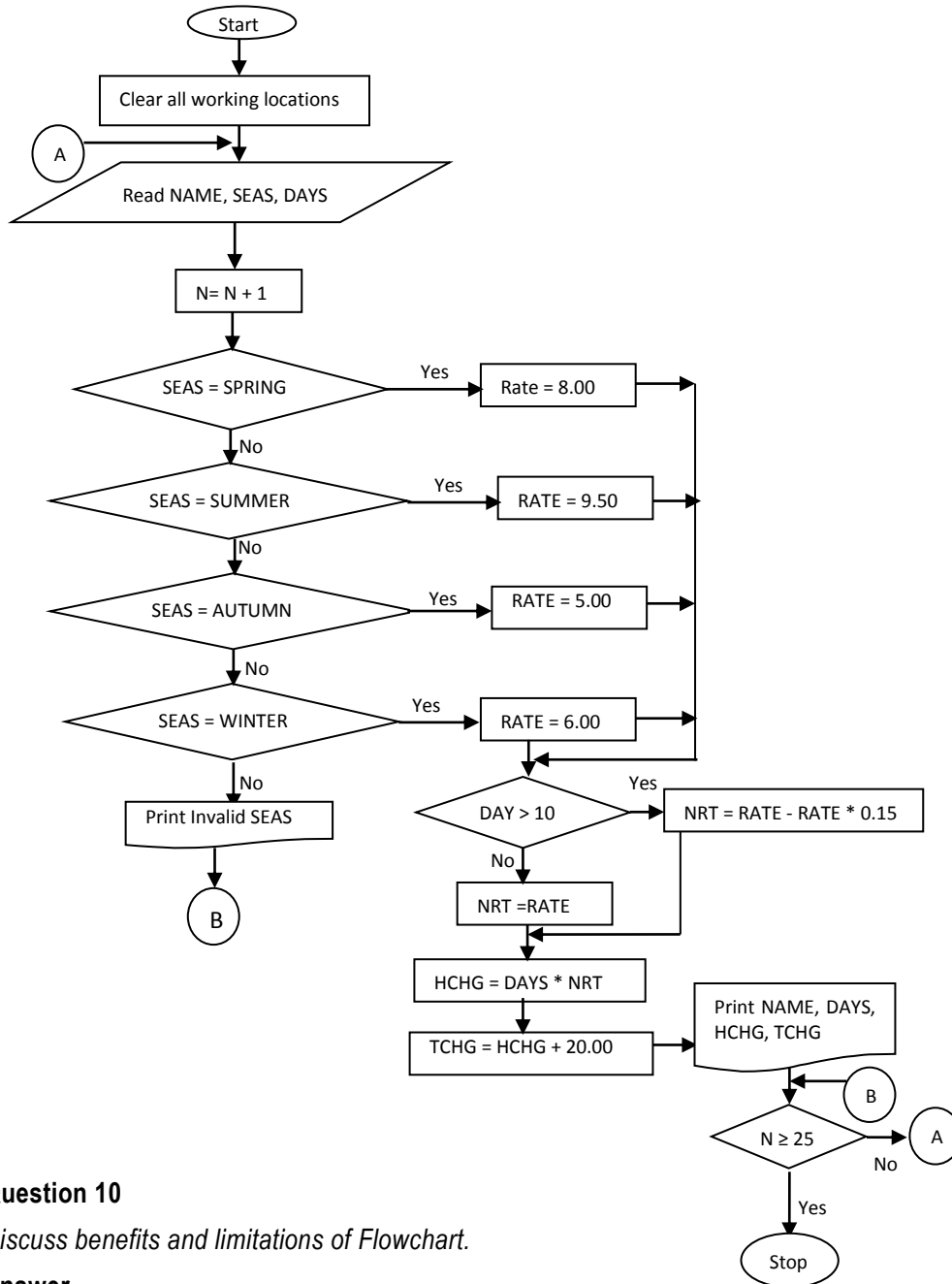

Question 10

Discuss benefits and limitations of Flowchart.

Answer

The **benefits** of flowcharts are elucidated below:

- (i) **Quicker grasp of relationships** – Before any application can be solved, it must be understood, the relationship between various elements of the application must be

1.18 Information Technology

identified. The programmer can chart a lengthy procedure more easily with the help of a flowchart than by describing it by means of written notes.

- (ii) **Effective Analysis** – The flowchart becomes a blue print of a system that can be broken down into detailed parts for study. Problems may be identified and new approaches may be suggested by flowcharts.
- (iii) **Communication** – Flowcharts aid in communicating the facts of a business problem to those whose skills are needed for arriving at the solution.
- (iv) **Documentation** – Flowcharts serve as a good documentation which aid greatly in future program conversions. In the event of staff changes, they serve as training function by helping new employees in understanding the existing programs.
- (v) **Efficient coding** – Flowcharts act as a guide during the system analysis and program preparation phase. Instructions coded in a programming language may be checked against the flowchart to ensure that no steps are omitted.
- (vi) **Orderly check out of problem** – Flowcharts serve as an important tool during program debugging. They help in detecting, locating and removing mistakes.
- (vii) **Efficient program maintenance** – The maintenance of operating programs is facilitated by flowcharts. The charts help the programmer to concentrate attention on that part of the information flow which is to be modified.

The **limitations** of flowcharts are given below:

- (i) **Complex logic** – Flowchart becomes complex and clumsy where the problem logic is complex. The essentials of what is done can easily be lost in the technical details of how it is done.
- (ii) **Modification** – If modifications to a flowchart are required, it may require complete re-drawing.
- (iii) **Reproduction** – Reproduction of flowcharts is often a problem because the symbols used in flowcharts cannot be typed.
- (iv) **Link between conditions and actions** – Sometimes it becomes difficult to establish the linkage between various conditions and the actions to be taken there upon for a particular condition.
- (v) **Standardization** – Program flowcharts, although easy to follow, are not such a natural way of expressing procedures as writing in English, nor are they easily translated into Programming language.

Question 11

What are the various key factors to be considered in implementing Business Process Management (BPM) in an enterprise?

Answer

Various key factors to be considered in implementing Business Process Management (BPM) in an enterprise are as follows:

Factors	Key Considerations
Scope	A single process, a department, the entire company.
Goals	Process understanding, Process Improvement, Process Automation/ Optimization and Process re-engineering.
Methods to be used	Six Sigma, BPM Life Cycle Method, TQM, Informal methods.
Skills Required	Consultants, Train Employees, Formal Certification, Basic Education, Existing Skill sets.
Tools to be used	White-Boards, Sticky Notes, Software For Mapping, Documenting, Software for Simulation, Comprehensive BPMS.
Investments to Make	Training, Tools, Time.
Sponsorship/Buy-in Needed	Executive Level, Department Level, Process Owner Level, Employee Level.

Question 12

What are the major reasons for failure of Business Process Management System (BPMS)?

Answer

Major reasons for the failure of Business Process Management Systems (BPMS) include the following:

- Inadequate investment in ongoing training for involved personnel;
- Lack of corporate policy protecting the integrity of the data in the BPM Systems;
- Superficial or deficient executive involvement;
- Deficient project management;
- Breakdown in gap analysis;
- Limited options for customization of the BPM software are required;
- Not flexible enough or too complicated to be customized to meet the precise workflow and business process;
- Failure to identify future business needs;
- Inadequate assessment of the need for change management;
- Persistent compatibility problems with the diverse legacy systems of the partners;
- Resources not available when desirable;
- Software fails to meet business needs;
- System may be over-engineered when compared to the actual requirements; and
- Technological obsolescence.

Question 13

What are the key benefits of Business Process Automation (BPA)?

1.20 Information Technology

Answer

The key benefits of Business Process Automation are as follows:

- **Saving on costs:** Automation leads to saving in time and labor costs through higher efficiency and better management of the people involved.
- **Staying ahead in competition:** Today, to survive, businesses need to adopt automation.
- **Fast service to customers:** Automation shortens cycle times in the execution of processes through improved and refined business workflows and help enterprises to serve their customers faster and better.
- **Reducing the impact of human error:** BPA removes human participation in the process, which is the source of many errors.
- **Transforming data into information:** BPA can, apart from collecting and storing data also analyze data and make it available in a form that is useful for decision-making.
- **Improving performance and process effectiveness:** In many cases, tasks that must be done manually are the bottlenecks in the process. Automating those manual tasks, speeds up the effective throughput of the application.
- **Making users more efficient and effective:** People can focus their energies on the tasks they do best, allowing the computers to handle those that machines are best suited for.
- **Making the business more responsive:** Enterprises can easily automate new applications and processes as they are introduced that provide greater control over business and IT processes.
- **Improving collaboration and information sharing:** Business processes designed through a collaborative mean IT can integrate its processes with the business -side logic that drives day-to-day operations.

Question 14

ABC Limited is a software development company, which appointed 50 software engineers in August' 2014 at a monthly salary of ₹ 30,000. All these engineers shall be entitled for an increment in their monthly salary after six months. The increment on present monthly salary shall be based on their performance to be evaluated on a 100 marks scale as per details given below:

- *Performance Marks < 70, then increment shall be 10% of present salary.*
- *70 ≤ Performance marks < 80, then increment shall be 20% of present salary.*
- *Performance marks ≥ 80, then increment shall be 30% of present salary.*

Draw a Flow-Chart to enable to print the details like name of the engineer, performance marks, monthly increment amount and revised monthly salary for each of these 50 engineers.

Answer

(a) Let us define the variables first:

PM: Performance Marks, **RESAL:** Revised Monthly Salary, **INCAMT:** Increment Amount, **NAME:** Name of Engineer, **N:** Pointer to track number of Engineers, **INCREMENT = 0.**

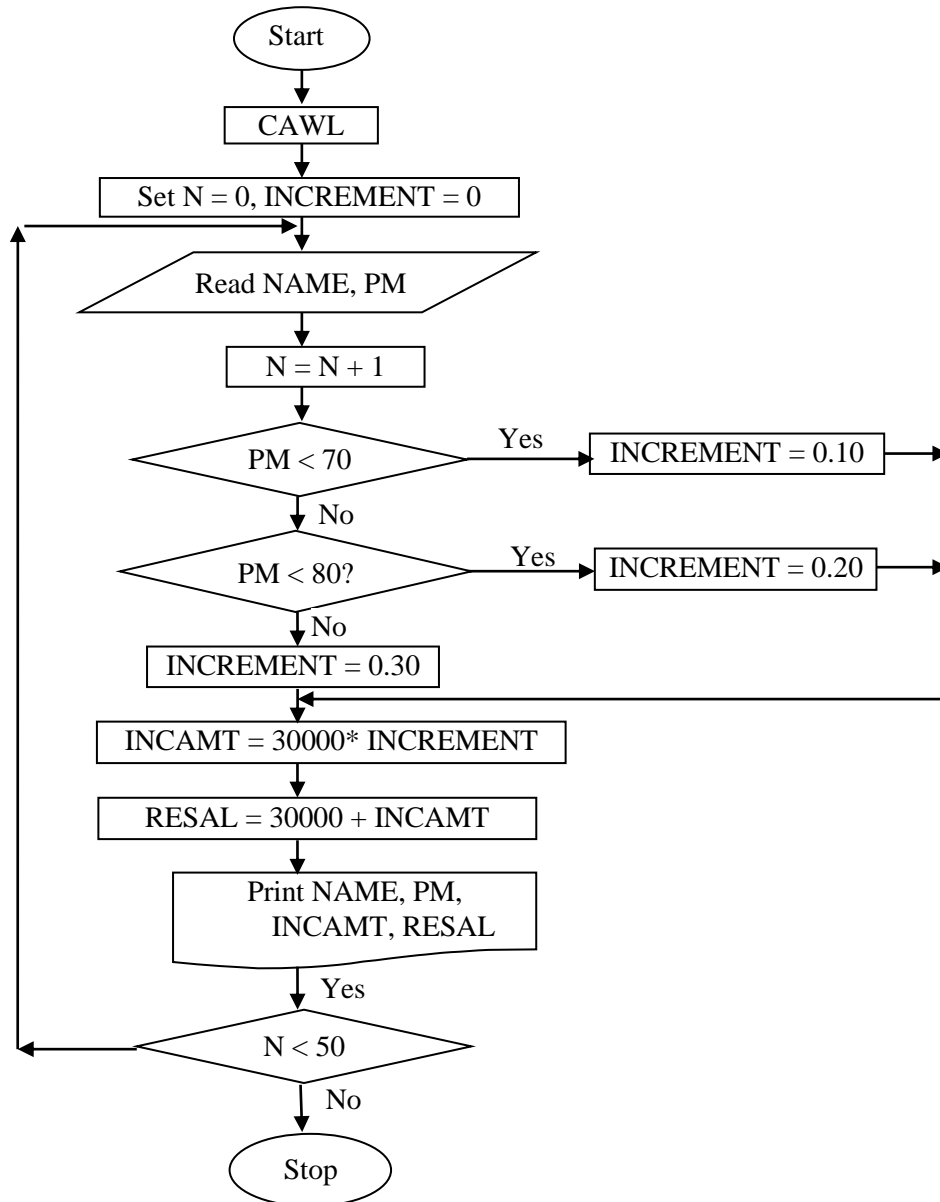

Question 15

Write short note on the following:

1.22 Information Technology

- (a) *Radical Redesign*
- (b) *Entity-Relationship Diagram*
- (c) *Business functions of Value Chain*

Answer

- (a) **Radical Redesign:** Radical redesign means that Business Process Reengineering (BPR) is reinventing and not enhancing or improving. In other words, BPR is based on the understanding that the products and services a company offers to the market are provided through business processes, and a radical redesign of these processes is the road to success. A radical rethinking on the way the business is run brings the finest out of the organization.
- (b) **Entity-Relationship Diagram:** An Entity-Relationship (ER) diagram is a data modeling technique that creates a graphical representation of the entities, and the relationships between entities, within an information system. ER diagrams repeatedly bring into play symbols to symbolize three dissimilar types of information. Boxes are commonly used to represent entities. Diamonds are normally used to represent relationships. A relationship is an association that exists between two entities.
- (c) Business functions of the Value Chain are as follows:
 - Research and Development;
 - Design of products, services, or processes;
 - Production;
 - Marketing and Sales;
 - Distribution; and
 - Customer Service

Question 16

Mention the challenges in implementing 'Business Process Automation'.

Answer

Some of the challenges in implementing Business Process Automation (BPA) are as follows:

- ◆ The number of interfaces with the customers is growing (e.g. phone, fax, email, sms, PDA, etc.);
- ◆ The product, service and price options have increased the complexity of the business;

- ◆ Most organizations have a whole suite of 'build and buy' systems and applications, often each with its own data format; and
- ◆ Budgets are being cut.

Question 17

An E-commerce site has the following cash back offers.

- (i) If the purchase mode is via website, an initial discount of 10% is given on the bill amount.*
- (ii) If the purchase mode is via phone app, an initial discount of 20% is given on the bill amount.*
- (iii) If done via any other purchase mode, the customer is not eligible for any discount.*

Every purchase eligible to discount is given 10 reward points.

- (a) If the reward points are between 100 and 200 points, the customer is eligible for a further 30% discount on the bill amount after initial discount.*
- (b) If the reward points exceed 200 points, the customer is eligible for a further 40% discount on the bill amount after initial discount.*

Taking purchase mode, bill amount and number of purchases as input; draw a flowchart to calculate and display the total reward points and total bill amount payable by the customer after all the discount calculation.

Answer

(a) Let us define the variables first:

PM: Purchase Mode

BA: Bill Amount

TBA: Total Bill Amount

NOP: Number of Purchases

TRP: Total Reward Points

IN_DISC: Initial Discount

ET_DISC: Extra Discount on purchases eligible to Initial Discount

N: Counter (to track the number of purchases)

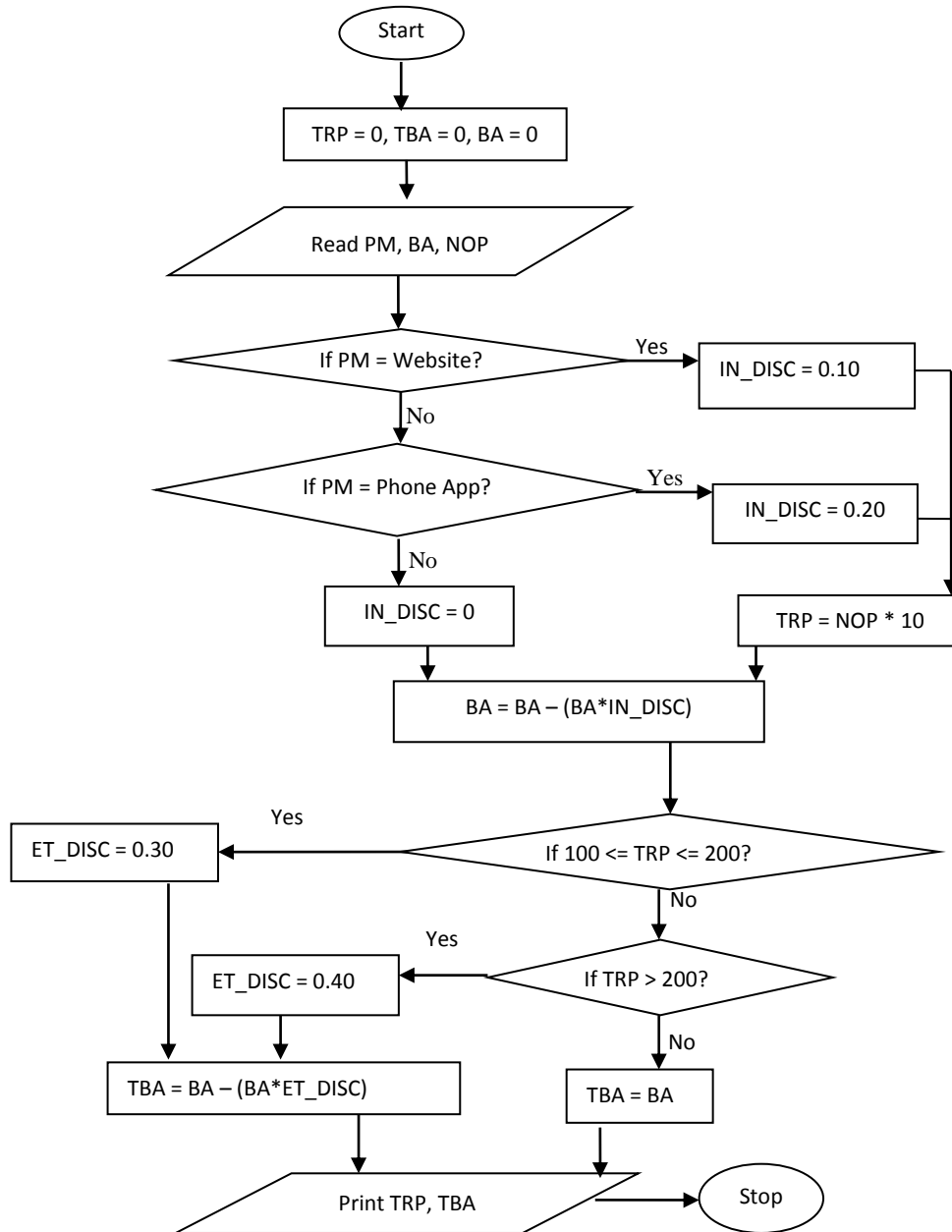

Question 18

ABC Limited is planning to implement Business Process Management Systems (BPMS). The Management asked you to briefly explain some benefits of BPMS to help them to take a decision on BPMS.

Answer

Some of the benefits of Business Process Management Systems (BPMS) are as follows:

- (a) **Automating repetitive business processes:** Processes such as report creation and distribution or the monitoring of or reporting on company's Key Performance Indicators (KPI) reduces the manual operational costs and helps employees to concentrate on activities that are important to the success of business.
- (b) **BPMS works by 'loosely coupling' with a company's existing applications:** This enables it to monitor, extract, format and distribute information to systems and people; in line with business events or rules.
- (c) **Operational Savings:** BPM focuses on optimization of processes. The processes that are repetitive are optimized and lead to reduced expenses which translate to immediate cost savings. By automating a task, ROI of BPM that requires six hours of manual intervention, one can expect to cut that time to half. Thus, three hours multiplied by the number of times the process is completed in a cycle will yield significant cost saving.
- (d) **Reduction in the administration involved in Compliance and ISO Activities:** Be it a quality assurance initiative such as the ISO standards, a financial audit law, or an IT systems best-practice implementation, companies worldwide are seeing the need to manage compliance as part of their everyday business activities. The BPM is ideally suited to help support companies in their quest for process improvement and compliance/governance certification. It gives full control over process and document change, clarity of inherent risks, and ease with which process knowledge is communicated across the company.
- (e) **Freeing-up of employee time:** While the euphuism "time is money" is often over-used, it is very relevant to this topic, because in business, for each additional hour it takes to complete a manual business process, there is a hard cost associated with employee time as well as soft costs associated with losing business or lowered productivity. Another area where time comes into play is in opportunity costs.

Question 19

A company ABC Ltd. is engaged in selling consumer goods to different categories of customers. In order to increase its sales, different types of discounts are offered to customers. The policy of discount is as given below:

- (i) *On cooking range, a discount of 12 percent is allowed to dealers and 9 percent to retailers irrespective of the value of the order.*
- (ii) *A discount of 12 percent is allowed on washing machine irrespective of the category of customer and the value of the order.*

1.26 Information Technology

(iii) On decorative products, dealers are allowed a discount of 20 percent provided that the value of the order is ₹ 10,000 and above. Retailers are allowed a discount of 10 percent irrespective of the value of the order.

Draw a flow chart to calculate the discount for the above policy.

Answer

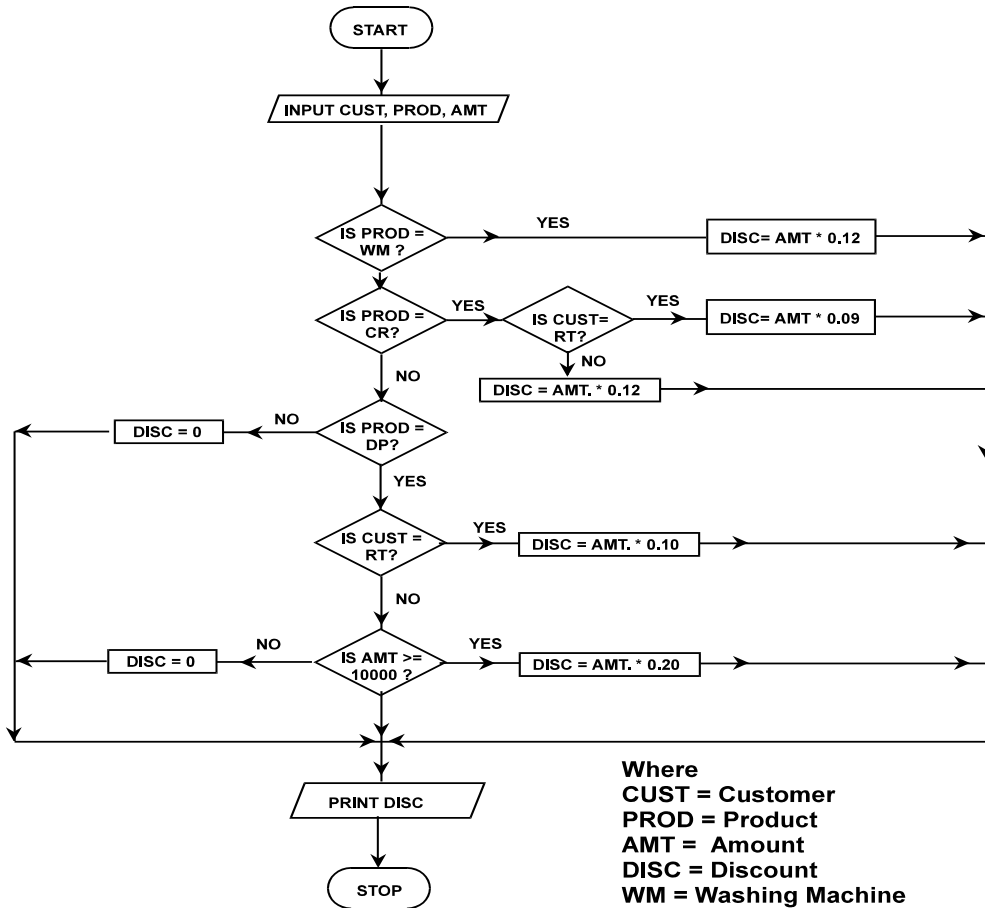

Where
 CUST = Customer
 PROD = Product
 AMT = Amount
 DISC = Discount
 WM = Washing Machine
 CR = Cooking Range
 DP = Decorative Product
 RT = Retailer

Question 20

A bank has 500 employees. The salary paid to each employee is sum of his basic pay, Dearness Allowance and House rent allowance. For the purpose of computing house rent allowance bank has classified his employees into three classes A, B and C. The house rent allowance for each class is computed at the rate of 30 percent, 20 percent and 10 percent of the basic pay respectively. The dearness allowance is computed at a flat rate of 60 percent of

the basic pay. Draw a flow chart to determine the percentage of employee falling in the each of the following salary slabs:

- (i) Above ₹ 30,000
- (ii) ₹ 15,001 to ₹ 30,000
- (iii) ₹ 8,001 to ₹ 15,000
- (iv) Less than or equal to ₹ 8,000.

Answer

Abbreviations used are as follows:

- P₁: Percentage of employees falling in salary slab (salary ≤ 8,000);
- P₂: Percentage of employees falling in salary slab (8,001 ≤ salary ≤ 15,000)
- P₃: Percentage of employees falling in salary slab (15,001 ≤ salary ≤ 30,000)
- P₄: Percentage of employees falling in salary slab (salary ≥ 30,000)
- I: Count of number of employees

The required flowchart is given below in Fig. 1:

Question 21

Write in brief the advantages and limitations of using E-R Diagram.

Answer

Advantages of using Entity-Relationship (E-R) Diagram are as follows:

- *ER Modeling is simple and easily understandable. It is represented in business users' language and it can be understood by non-technical specialist.*
- *Intuitive and helps in Physical Database creation.*
- *Can be generalized and specialized based on needs.*
- *Can help in database design.*
- *Gives a higher-level description of the system.*

Limitations of using E-R Diagram are as follows:

- *Physical design derived from E-R Model may have some amount of ambiguities or inconsistency.*
- *Sometime diagrams may lead to misinterpretations.*

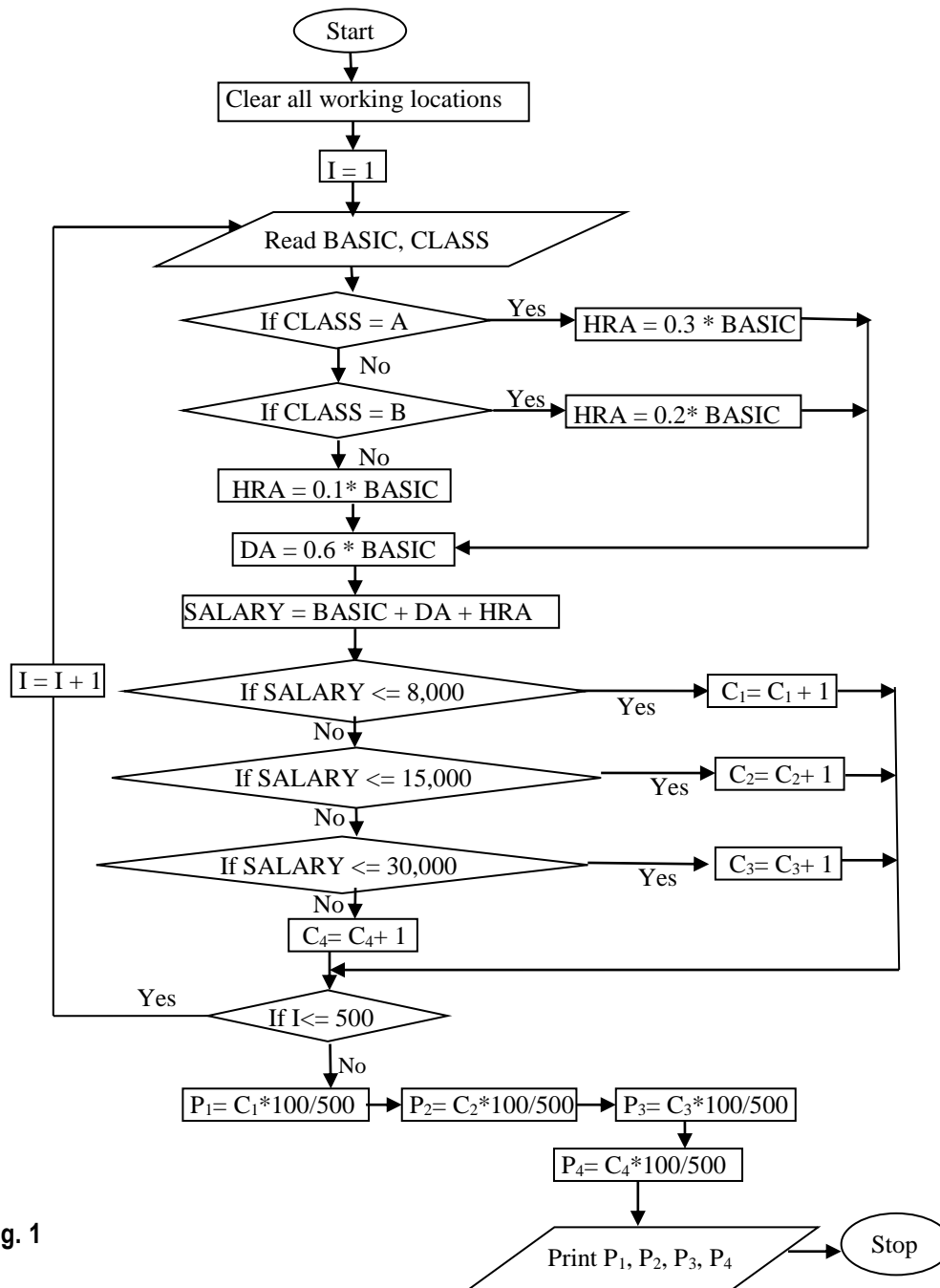

Fig. 1

Question 22

Discuss the Data Flow Diagram (DFD) and its components. Also, briefly mention about its types.

Answer

Data Flow Diagram (DFD) is a graphical representation of the flow of data through an information system. A DFD illustrates technical or business processes with the help of the external data stored, the data flowing from a process to another, and the results. DFDs may be partitioned into levels that represent increasing information flow and functional detail. Therefore, the DFD provides a mechanism for functional modeling as well as information flow modeling.

The major components of DFD are as follows:

- (i) **Entity:** An entity is the source or destination of data. The entities either provide data to the system (Source) or receive data from it (Sink).
- (ii) **Process:** The process is the manipulation or work that transforms data, performing computations, making decisions (logic flow), or directing data flows based on business rules.
- (iii) **Data Store:** A data store is where a process stores data between processes for later retrieval by that same process or another one.
- (iv) **Data Flow:** Data flow is the movement of data between the entity, the process and the data store.

The types of Data Flow Diagrams (DFDs) are as follows:

- **Logical Data Flow Diagram:** A Logical DFD focuses on the business and how the business operates. It describes the business events that take place and the data required and produced by each event. The logical model reflects the business.
- **Physical Data Flow Diagram:** A Physical DFD shows how the system will be implemented. The physical model depicts the system.

Question 23

Discuss the reasons why documentation is important to Information Systems.

Answer

Some of the reasons why documentation is important to Information Systems are as follows:

- **Depicting how the system works:** In computerized systems, the processing is electronic and invisible. Therefore, documentation is required to help employees understand how a system works, assist accountants in designing controls for it, demonstrates to managers that it will meet their information needs, and assists auditors in understanding the systems that they test and evaluate.
- **Training users:** Documentation also includes user guides, manuals, and similar operating instructions that help people learn how an Information System operates. These documentation aids help train users to operate Information systems hardware and software, solve operational problems, and perform their jobs better.

- **Designing new systems:** Documentation helps system designers develop new systems in much the same way that blueprints help architects design building, Well-written documentation and related graphical systems-design methodologies play key roles in reducing system failures and decreasing the time spent correcting emergency errors.
- **Controlling system development and maintenance costs:** Personal computer applications typically employ prewritten, off-the-shelf software that is relatively reliable and inexpensive. Good documentation helps system designers develop object-oriented software, which is software that contains modular, reusable code that further avoid writing duplicate programs and facilitate changes when programs must be modified later.
- **Standardizing communications with others:** Documentation aids such as E-R Diagrams, System Flowcharts, and Data Flow Diagrams are more standardized tools, and they are more likely to be interpreted the same way by all parties viewing them. Thus, documentation tools are important because they help describe an existing or proposed system in a common language and help users communicate with one another about these systems.
- **Auditing Information Systems:** Documentation helps depict audit trails. For example- when investigation in an Accounting Information system, the auditors typically focus on internal controls. In such circumstances, documentation helps auditors determine the strengths and weaknesses of a system's controls and therefore the scope and complexity of the audit.
- **Documenting business processes:** Understanding business processes can lead to better systems and better decision. Documentation helps managers better understand how their businesses operate what controls are involved or missing from critical organizational activities, and how to improve core business activities.

Question 24

Discuss in brief the success factors of Business Process Re-engineering (BPR).

Answer

Some of the Business Process Re-engineering (BPR) Success factors are as follows:

- Organization wide commitment:** Changes to business processes would have a direct impact on processes, organizational structures, work culture, information flows, infrastructure & technologies and job competencies. This requires strong leadership, support and sponsorship from the top management. Top management not only has to recognize the need for change but also must convince every affected group about the potential benefits of the change to the organization as a whole and secure their commitment.
- BPR team composition:** A BPR team is formed which would be responsible to take the BPR project forward and make key decisions and recommendations. The BPR team would include active representatives from top management, business

process owners, technical experts and users. It is important that the teams must be kept of manageable size (say 10 members) to ensure well-coordinated, effective and efficient completion of the entire BPR process.

- (iii) **Business needs analysis:** It is important to identify exactly what current processes need reengineering. This would help determine the strategy and goals for BPR. A series of sessions are held with the process owners and stakeholders and all the ideas would be evaluated to outline and conceptualize the desired business process. The outcome of this analysis would be BPR project plan – identifying specific problem areas, setting goals and relating them to key business objectives. This alignment of the BPR strategy with the enterprise strategy is one of the most important aspects.
- (iv) **Adequate IT infrastructure:** Adequate investment in IT infrastructure in line is of vital importance to successful BPR implementation. An IT infrastructure is a set of hardware, software, networks, facilities, etc. (including all of the information technology), in order to develop, test, deliver, monitor, control or support IT services. Effective alignment of IT infrastructure to BPR strategy would determine the success of BPR efforts.
- (v) **Effective change management:** BPR involves changes in people behavior and culture, processes and technologies. Hence, resistance would be a natural consequence which needs to be dealt with effectively. An effective change management process would consider the current culture to foster a change in the prevailing beliefs, attitudes and behaviors effectively. The success of BPR depends on how effectively management conveys the need for change to the people.
- (vi) **Ongoing continuous improvement:** BPR is an ongoing process hence innovation and continuous improvement are key to the successful implementation of BPR.

Question 25

Draw a Flowchart for the following process:

Leebay is a new e-commerce web site that is setting up business in India. Leebay and their partner bank Paxis have come up with a joint promotion plan for which the following offers are proposed. Customers can either log in through a mobile app or directly from the website:

- (1) If the payment mode chosen is 'Paxis Credit', then a 20% discount is given to the user.
- (2) If the payment mode chosen is 'Paxis Debit', then a 10% discount is given to the user.
- (3) If other payment modes are used, then no discount is given.

Also, to promote the downloads of its new smartphone app, the company has decided to give the following offer:

- (1) If the purchase mode is 'Mobile App', then no surcharge is levied on the user.

1.32 Information Technology

- (2) If any other purchase mode is used, then additional 5 surcharge is levied on the user. This surcharge is applied on the bill after all necessary discounts have been applied.

With bill amount, payment mode and purchase mode as inputs, draw a flowchart for the billing procedure for Leebay.

Answer

Variables need be defined implying following:

PU_MODE: Purchase Mode, **BILL_AMT**: Initial Bill Amount, **TOT_BILL_AMT**: Bill Amount after Discount, **SCHG**: Surcharge, **FIN_BILL_AMT**: Final Bill Amount after Surcharge, **DISC** : Discount, **PMT_MODE**: Payment Mode

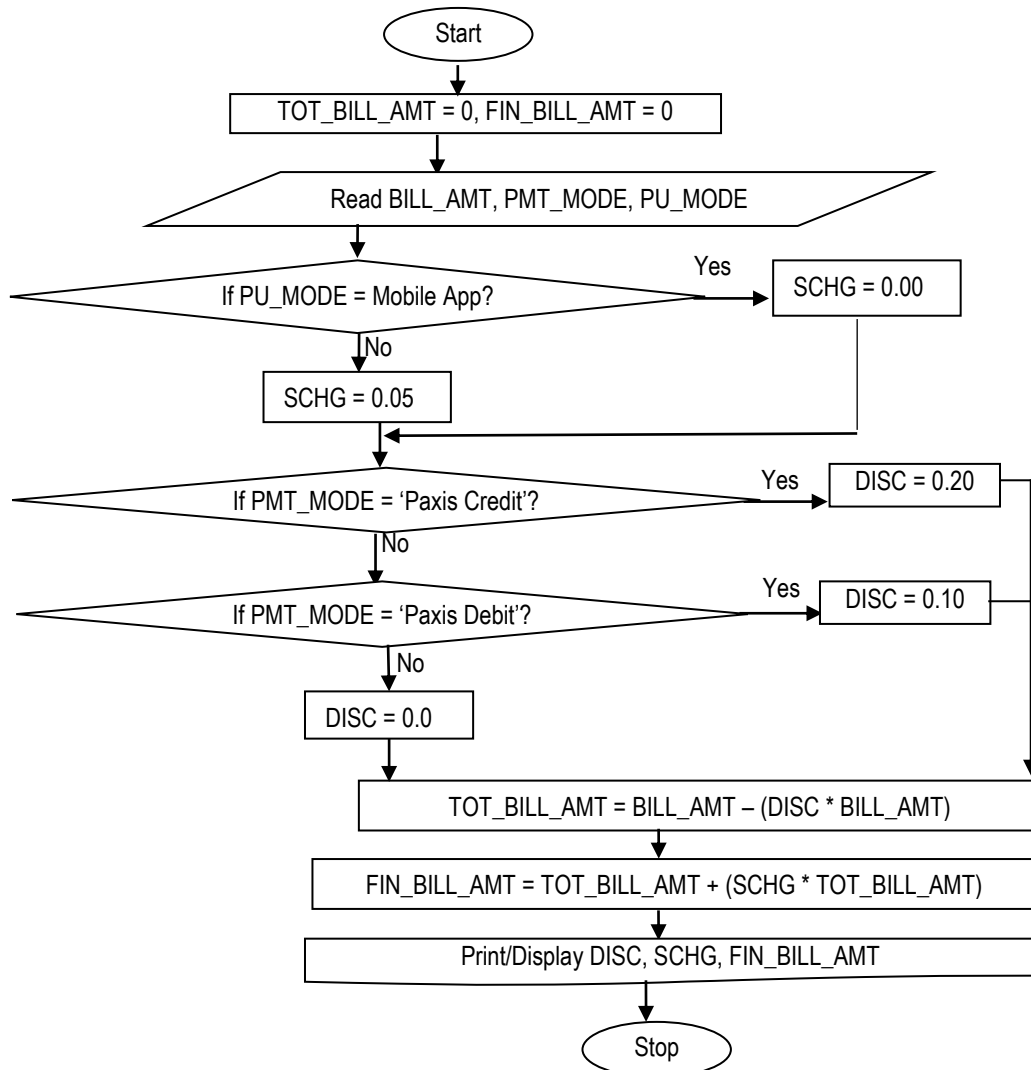

Exercise

1. What are the key goals of Business Process Management?
2. Discuss the benefits of Business Process Management System.
3. In a school, students are allocated to different classes. Each student must be allocated to exactly one class, and a class is formed by atleast 30 students. Each class must be managed by several different students, namely, prefect, 1st monitor, 2nd monitor and 3rd monitor. Draw an E-R diagram for the school, indicating cardinality.
4. For computing custom duty, the imported items are classified into 4 categories. The rate of duty to be levied on each category of items is given below:

Category (K)	Class of Goods	% Custom duty on the value of goods (V)
1	Food and Beverages	10
2	Textile and Leather goods	15
3	Heavy Machinery	20
4	Luxury Items	40

Draw a flowchart to compute the custom duty.

5. Draw a flowchart to compute and print the income-tax and surcharge on the income of a person, where income is to be read from terminal and tax is to be calculated as per the following rates:

Upto ₹ 40,000	No Tax
Upto ₹ 60,000	@ 10% of amount above ₹ 40,000
Upto ₹ 1,50,000	₹ 2,000 + 20% of amount above ₹ 60,000
Above ₹ 1,50,000	₹ 20,000 + 30% of amount above ₹ 1,50,000

Charge surcharge @ 2% on the amount of total tax if the income of a person exceeds ₹ 2,00,000.

6. Discuss advantages and limitations of the following:
 - (a) Decision Table
 - (b) Data Flow Diagram
 - (c) Decision Tree

2

Information Systems and IT Fundamentals

2.1 Introduction

Information Technology is a key enabler in modern enterprises and the relevance of IT on auditing in terms of risks; security, control and changes required in audit process and procedures; cannot be ignored. Any enterprise needs effective and efficient ways to use Business Process Automation (BPA), which is largely aided by Information Technology. Information Systems, which forms the backbone of any enterprise comprises of various layers such as: Application Software; Database Management Systems (DBMS); System Software; Hardware; Network Links and People-Users. Further, whenever an information system has to be deployed for the first time or some major changes are required, we need to implement Information System Life Cycle. This has different phases which encompass System Development, System Investigation, System Analysis, System Design, System Implementation, System Maintenance and Review.

2.2 Need for Information Technology

Understanding 'How IT is deployed in enterprises' is imperative to learning about business. IT in the present context may be referred as a computer-based tool that people use to work with information and support the information-processing needs of an enterprise. IT allows enterprises to work more efficiently and to maximize productivity. Faster communication, electronic storage and the protection of records are advantages that IT can give to any enterprise. IT enables business enterprises to differentiate their products and services from their competitors.

2.2.1 Communication Capabilities

IT provides resources to enterprises to communicate quickly and effectively. With these communication capabilities, enterprises can now integrate their business functions and segments spread across different geographical areas. Any global enterprise having an international presence can integrate its far flung business locations using communication capabilities offered by IT.

Some of the common and efficient communication tools are Emails, Voice over Internet Protocol (VoIP), WhatsApp Messenger etc. Skype is one such popular VoIP service, which allows people across the world to make free, unlimited, superior quality voice calls via its innovative peer-to-peer software.

2.2.2 Data and Information Management
<p>Today, most enterprises store digital versions of documents on servers, storage devices and on cloud. These documents are instantly available to anyone with access rights, regardless of their geographical location. Further, IT also enables Information Security encompassing the protection of information from accidental or intentional misuse by persons inside or outside an enterprise. IT security engineering systems protect enterprise electronic information from being hacked, or wiped out during a technological disaster.</p>
2.2.3 Automated Processes
<p>Business Process Automation (BPA) is a strategy that is used to optimize and streamline the essential business processes, using the latest technology to automate the functions involved in carrying them out. BPA allows the organizations to extract maximum benefit by using the available resources to their best advantage, while keeping the operational cost as low as possible. Doing so helps the enterprise to generate greater profits and achieve a level of stability that would be hard to realize without the use of automation.</p>
2.3 Importance of IT in Auditing
<p>Information Technology encompasses all aspects of functioning of enterprises from strategy to operations, conception to completion and from ideation to value creation. Enterprises, professionals as individuals are becoming increasingly dependent on IT and understand the need to embrace IT. Information Technology is evolving at an accelerating pace and the role of IT is transforming business processes. Auditors provide solutions to complex issues by integrating specialized technology with their extensive experience to create new strategic business processes. They provide assurance on the security; effectiveness and reliability of information; applications; and new and effective business practices and processes.</p>
2.3.1 Auditing in IT Environment
<p>Audit broadly would involve the process of evaluating and reporting the adequacy of system controls, efficiency, economy, effectiveness, and security practices to assure that assets and information resources are safeguarded; that data integrity is protected; and that the system complies with applicable policies, procedures, standards, rules, laws and regulations.</p>
2.3.2 IT Risks and Issues
<p>It becomes critical for enterprises to implement IT not only with right security but also to create business value. Auditors can play a critical role in reviewing security and facilitating enterprises to realize business value. Enterprise risks include several components such as business risks, technology risks, operational risk and other risks.</p> <p>Technology risks are faced by enterprises that are heavily driven by and dependent on technology, especially where the types of technology used are rare and keep changing. When the technology used fails or becomes obsolete, the enterprise may not be able to continue with its business.</p>

2.3 Information Technology

2.3.3 Need for Controls in Information Systems

With the advent of affordable hardware, technology has become a critical component of business. Today's dynamic global enterprises need information integrity, reliability and validity for timely flow of accurate information throughout the organization. A well designed information system should have controls built-in for all its sensitive or critical sections.

Information System Control procedure may include Strategy and Direction; General Organization and Management; Access to IT resources including data and programs; System Development Methodologies and Change Control; Operation Procedures; System Programming and Technical Support Functions; Quality Assurance Procedures; Physical Access Controls; Business Continuity Planning (BCP) and Disaster Recovery Planning (DRP); Network and Communication; Database Administration; and Protective and Detective mechanisms against internal and external attacks.

2.3.4 Special features of auditing in an IT environment

Auditors in an IT environment are to know the methodology of audit to ensure the proper performance of audit being carried out.

2.3.5 Impact of IT on Risks and Controls

Data handling capacity of computer combined with telecommunications technology greatly increases ability of an individual to access and perhaps to manipulate large quantities of data - within a relatively short time period: thus, increasing amount of potential damage or risk of exposure.

2.3.6 Auditors' Concern

The increased risks and changes in traditional control functions lead to a shift in the auditors concern. The key concerns of auditor are to develop and apply new criteria in evaluating control weaknesses in Computerized Information Systems (CIS) and to use computers to perform some portions of audit examination.

2.4 Business Process Automation

Business Process Automation (BPA) is a process of managing information, data and processes to reduce costs, resources and investment. BPA capabilities range from automating a simple data-entry-manipulation task to building complex, automated financial management processes using existing applications. The resulting benefits are cost reduction, elimination of human error, freeing people from routine and volume, and allow management to do what they are best at: make decisions, analyze data implications and trends and focus on providing better customer service.

The steps involved in any BPA are as follows:

Step 1	Define why we plan to implement BPA?
Step 2	Understand the rules/ regulation under which it needs to comply with?
Step 3	Document the process, we wish to automate.
Step 4	Define the objectives/goals to be achieved by implementing BPA.
Step 5	Engage the business process consultant.
Step 6	Calculate the ROI for project.
Step 7	Development of BPA.
Step 8	Testing the BPA.

2.4.1 Business Process Management

Business Process Management (BPM) is the methodology used by enterprises to improve end-to-end business processes in various stages. An Enterprise Resource Planning (ERP) application divides BPM into the phases: **Analysis, Design, Implementation, Run & Monitor** and **Optimize**. BPA makes existing processes more efficient, not only at enterprise level but even for desktop users' through simple workflows, access and authorizations. BPA application ties up these activities – **Integration, Orchestration and Automation**.

2.5 Computing

Computing may be defined as any goal-oriented activity requiring, benefiting from or creating computers. It includes designing and building hardware and software systems for a wide range of purposes; processing, structuring, and managing various kinds of information; doing scientific studies using computers; making computer systems behave intelligently; creating and using communications and entertainment media; finding and gathering information relevant to any particular purpose, and so on.

2.6 Computing Technologies

Brief overview of some of the key computing technologies are given as follows:

2.6.1 Server

From a hardware perspective, a server is a computer (hardware) or device on a network dedicated to run one or more services (as a host), to serve the needs of the users of other computers on a network. In client-server architecture, a server is a computer program running to serve the requests of other programs, the "clients". Thus, the server performs some computational task on behalf of "clients". The clients either run on the same computer or they connect through the network. Servers are often dedicated, meaning that they perform no other tasks besides their server tasks.

2.6.2 Popular Computing Architecture

Computer architecture is the art that specifies the relations and parts of a computer system. In computer engineering, Computer Architecture is the conceptual design and fundamental operational structure of a computer system. The computer is based on a fixed hardware platform capable of executing a fixed repertoire of instructions. CPU, the centre piece of the computer's architecture, is in charge of executing the instructions of the currently loaded program. These instructions tell the CPU to carry out various calculations, to read and write values from and into the memory, and to conditionally jump to execute other instructions in the program. Popular computing architecture used today is called **Instruction Set Architecture (ISA)**. Computer architecture includes at least three main subcategories: **Instruction Set Architecture, Micro-Architecture and System Design**.

2.6.3 Emerging Computing Models

(I) Cloud Computing: Cloud Computing is the use of various services such as software development platforms, servers, storage, and software over the Internet, often referred to as the "cloud."

A. Cloud Computing Environment: The cloud computing environment can consist of multiple types of clouds based on their deployment and usage – **Public, Private, Community and Hybrid**.

B. Cloud Computing Architectural Considerations: A cloud computing architecture consists of two parts - **Front End** and a **Back End** that connect to each other through a network, usually the Internet.

C. Service Models of Cloud Computing: Mainly, there are five Cloud Computing Service based models. These are **Information as a Service (IaaS), Software as a Service (SaaS), Platform as a Service (PaaS), Network as a Service (NaaS)** and **Communication as a Service (CaaS)**.

(II) Mobile Computing: Mobile Computing is the use of portable computing devices (such as laptop and handheld computers) in conjunction with mobile communications technologies to enable users to access the Internet and data on their home or work computers from anywhere in the world. It is a human-computer interaction by which a computer is expected to be transported during normal usage. Mobile computing involves **Mobile Communication, Mobile Hardware and Mobile Software**.

A. Business Applications of Mobile Computing: Mobile devices provide the capability to conduct business anywhere and enable users to seamlessly communicate and access information whether they are in the office or anywhere. The change driven largely by video, web-browsing, gaming and other entertainment related applications is one of the hottest trends in the consumer sector.

B. Mobile Computing Concerns: Major concerns relating to mobile computing are dangers of misrepresentation; Power consumption; and security concerns.

2.7 Information System Layers		
The layers are discussed as follows:		
	Component	Explanation
2.7.1	Application Software	This includes all those computer software that cause a computer to perform useful tasks beyond the running of the computer itself. Application Suite, Enterprise Software, Enterprise Infrastructure Software, Information Worker Software, Content Access Software, Educational Software and Media Development Software are the application software.
2.7.2	Database Management Systems (DBMS)	DBMS are software that aid in organizing, controlling and using the data needed by the application programme. Commercially available DBMS are Oracle, My SQL, SQL Servers and DB2 etc.
2.7.3	System Software	System software is computer software that is designed to operate the computer hardware and to give and maintain a platform for running application software. Example - Operating System.
2.7.4	Hardware	Hardware basically consists of devices that perform the functions of input, processing, data storage and output activities of the computer.
2.7.5	Network Links	Effective and efficient communication is a valuable resource which helps in good management. To enable this communication, we need communication networks.
2.7.6	People/Users	The people involved include users of the system and information systems personnel, including all the people who manage, run, program, and maintain the system.
2.8 Information System Life Cycle		
This is commonly referred as Software/System Development Life Cycle (SDLC) , which is a methodology used to describe the process of building information systems. It is the logical starting point in the entire life cycle of a computerized system. SDLC framework provides a sequence of activities for system designers and developers to follow. It consists of a set of steps or phases in which each phase of the SDLC uses the results of the previous one. An SDLC adheres to important phases that are essential for developers, such as Investigation; Analysis, Design; Implementation and Maintenance and Review.		

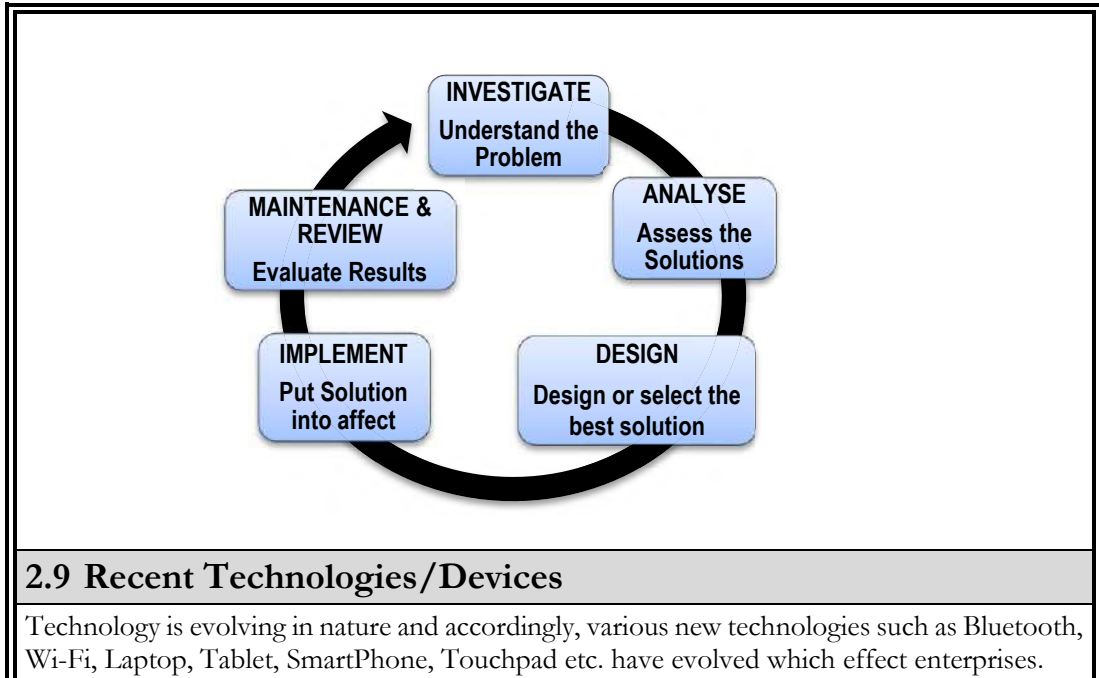

Question 1

Define the following:

- (a) Multiprocessing
- (b) Hardware Virtualization
- (c) Cloud Computing
- (d) Groupware
- (e) Computer Bus
- (f) Memory Controller
- (g) Direct Memory Access (DMA)

Answer

- (a) **Multiprocessing:** Multiprocessing is the use of two or more Central Processing Units (CPUs) within a single computer system to allocate tasks between them.
- (b) **Hardware Virtualization:** Hardware Virtualization or Platform Virtualization refers to the creation of a virtual machine that acts like a real computer with an operating system. Software executed on these virtual machines is separated from the underlying hardware resources.
- (c) **Cloud Computing:** Cloud computing is the use of various services, such as software development platforms, servers, storage, and software, over the Internet, often referred to as the "cloud."

- (d) **Groupware:** Groupware also known as Team-ware, Collaboration Software is software that allows collective and collaborative working of teams from different geographical locations on an online and real-time basis.
- (e) **Computer Bus:** Computer Bus is a communication system that transfers data between components inside a computer, or between computers that covers all related hardware components (wire, optical fiber, etc.) and software, including communication protocol.
- (f) **Memory Controller:** Memory Controller is a digital circuit which manages the flow of data going to and from the main memory and can be a separate chip or integrated into another chip.
- (g) **Direct Memory Access (DMA):** Direct Memory Access (DMA) is a feature of modern computers that allows certain hardware subsystems within the computer to access system memory independently of the Central Processing Unit (CPU).

Question 2

Write short notes on the following:

- (a) Bluetooth

Or

What is Bluetooth? Name some devices that utilize Bluetooth technology.

- | | |
|------------------------|--|
| (b) Wi-Fi | (c) Tablet |
| (d) SmartPhone | (e) Touchpad |
| (f) Notebook | (g) Cache Memory |
| (h) Virtual Memory | (i) Instruction Set Architecture (ISA) |
| (j) Micro Architecture | (k) Software as a Service (SaaS) |
| (l) Android | (m) WhatsApp Messenger |

Answer

- (a) **Bluetooth:** Bluetooth is a wireless technology standard for exchanging data over short distances up to 50 meters (164 feet) from fixed and mobile devices, creating personal Area Networks (PANs) with high levels of security. Bluetooth is like a very low-power, short-range radio signal which is secure from the moment they're sent, so unlike any other wireless network we don't have to worry about turning on security. Few devices that utilize Bluetooth technology are Keyboards and mice, Printers, mobile phones and headsets, PDAs (Personal Digital Assistants), Desktop and laptop computers, Digital cameras, and Remotes. Using a mobile phone with Bluetooth enabled; we can send pictures, videos, exchange business cards and transfer files to our PC. Both data and voice transmissions can be sent and received using short range networks.
- (b) **Wi-Fi:** Wi-Fi is a popular wireless networking technology that uses radio waves to provide wireless high-speed Internet and network connections. Wi-Fi networks have limited range.

2.9 Information Technology

A typical wireless access point might have a range of 32 meters (120 ft.). Wi-Fi can be less secure than wired connections because an intruder does not need a physical connection. Wi-Fi networks use radio technologies called 802.11 to provide secure, reliable, fast wireless connectivity. A Wi-Fi network can be used to connect electronic devices to each other, to the Internet, and to wired networks (which use Ethernet technology). Wi-Fi networks work well for small businesses providing connectivity between mobile salespeople, floor staff and behind-the-scenes finance and accounting departments.

- (c) **Tablet:** A Tablet computer, or simply tablet is a one piece general-purpose computer contained in a single panel. Its distinguishing characteristic is the use of a touch screen as the input device. Tablet PCs have extreme portability, easy to use interfaces and the wide range of ways they can be used. Some features of Tablets are as follows:
- ◆ **Input Method:** Tablets rely solely on a touch interface on the screen for all input.
 - ◆ **Size:** Tablets have the size roughly of a small pad of paper and a weight that is less than one Kg.
 - ◆ **Battery Life:** Tablets are designed for efficiency because of the low power requirements of their hardware components. Tablets can achieve all day usage.
 - ◆ **Storage Capacity:** Most tablets come with configurations that allow between 16 and 64 gigabytes of storage.
 - ◆ **Performance:** Most tablet PCs are based on extremely low powered processors more suited for tasks like email, web browsing, playing video or audio.
 - ◆ **Software:** The two major tablet platforms are Android and iOS amongst plenty of applications that are available.
 - ◆ **Wireless:** Because tablets by design are mobile computers; most of them have Wi-Fi, blue tooth and mobile connectivity.
- (d) **SmartPhone:** A SmartPhone is a mobile phone built on a mobile operating system with more advanced computing capability connectivity than a feature phone. This handheld device integrates mobile phone capabilities with the more common features of a handheld computer or PDA. Smartphone allows users to store information, e-mail and install programs, along with using a mobile phone in one device. Modern SmartPhones also include high-resolution touch screens and web browsers that display standard web pages as well as mobile-optimized sites. High-speed data access is provided by Wi-Fi and mobile broadband.
- (e) **Touchpad:** A Touchpad is a pointing device featuring a tactile sensor, a specialized surface that can translate the motion and position of a user's fingers to a relative position on screen. Touchpad is a common feature of laptop computers, can also be found on Personal Digital Assistants (PDAs) and some portable media players.
- (f) **Notebook:** Notebook is an extremely lightweight personal computer that typically weighs less than 3 Kg and is small enough to fit easily in a briefcase. Notebook computers use

flat-panel technologies to produce a lightweight and non-bulky display screen. Modern notebook computers are almost equivalent to personal computers having the same CPUs, memory capacity and disk drives.

- (g) **Cache Memory:** Cache Memory (pronounced as cash) is a smaller, faster memory which stores copies of the data from the most frequently used main memory locations so that Processor/Registers can access it more rapidly than main memory. It is the property of locality of reference, which allows improving substantially the effective memory access time in a computer system.
- (h) **Virtual Memory:** Virtual Memory is an imaginary memory area supported by some operating systems (for example, Windows) in conjunction with the hardware. If a computer lacks the Random Access Memory (RAM) needed to run a program or operation, Windows uses virtual memory to compensate. Virtual memory combines computer's RAM with temporary space on the hard disk. When RAM runs low, virtual memory moves data from RAM to a space called a paging file. Moving data to and from the paging file frees up RAM to complete its work. Thus, Virtual memory is an allocation of hard disk space to help RAM.
- (i) **Instruction Set Architecture (ISA):** It is the abstract model of a computing system that is seen by a machine language programmer, including the instruction set, memory address modes, processor registers, and address and data formats. Instruction Set Architecture (ISA) is related to the programming of a computer – that is, how the computer understands, what each element in its basic language means, what instructions are to be carried out and in what order, etc. The ISA basically deals with what the chip does.
- (j) **Micro architecture:** It, also known as Computer organization, is a lower level detailed description of the system that is sufficient for completely describing the operation of all parts of the computing system, and how they are inter-connected and inter-operate in order to implement the ISA. The Micro architecture can be seen as how the ISA does and what it does. It is the term used to describe the resources and methods used to achieve architecture specification. The term typically includes the way in which these resources are organized as well as the design techniques used in the processor to reach the target cost and performance goals. The micro architecture essentially forms a specification for the logical implementation.
- (k) **Software as a Service (SaaS):** It includes a complete software offering on the cloud. Users can access a software application hosted by the cloud vendor on pay-per-use basis. SaaS is a model of software deployment where an application is hosted as a service provided to customers across the Internet by removing the need to install and run an application on a user's own computer. SaaS can alleviate the burden of software maintenance and support but users relinquish control over software versions and requirements.
- (l) **Android:** Android is a Linux-based operating system designed primarily for touch screen mobile devices such as smart phones and tablet computers. Android is an open source and the permissive licensing allows the software to be freely modified and distributed by device manufacturers, wireless carriers and enthusiast developers. Android provides

2.11 Information Technology

access to a wide range of useful libraries and tools that can be used to build rich applications.

- (m) **WhatsApp Messenger:** It is a cross-platform mobile messaging application which allows us to exchange messages without having to pay for SMS. It is available for iPhone, BlackBerry, Android, Windows phone, Nokia and these phones can message each other. Because WhatsApp Messenger uses the same internet data plan that we use for e-mail and web browsing, there is no cost to message and stay in touch with friends.

Question 3

What are the three critical pillars of Business Process Automation (BPA)?

Answer

Business Process Automation rests on the following three critical pillars:

- ◆ **Integration:** BPA allows applications and operating systems not only to read data that the systems produce, but also to pass data between the component applications of the business process and to modify the data as necessary.
- ◆ **Orchestration:** The process of orchestration enables the ability to bring tasks that exist across multiple computers and different business departments or branches under one umbrella that is the business process itself.
- ◆ **Automation:** Orchestration and integration unite with automation to deliver the capability to provide a rule-based process of automatic execution that can span multiple systems and enable a more effective, nimble and efficient business process.

Question 4

Discuss some of the benefits of using Business Process Automation.

Answer

Some benefits of using Business Process Automation include:

- ◆ **Reducing the Impact of Human Error:** BPA removes human participation in the process, which is the source of many errors.
- ◆ **Transforming Data into Information:** BPA can, apart from collecting and storing data also analyze data and make it available in a form that is useful for decision-making.
- ◆ **Improving performance and process effectiveness:** In many cases, tasks that must be done manually are the bottleneck in the process. Automating those manual tasks speeds up the effective throughput of the application.
- ◆ **Making users more efficient and effective:** People can focus their energies on the tasks they do best, allowing the computers to handle those that machines are best suited for.
- ◆ **Making the business more responsive:** Business can easily automate new applications and processes as they are introduced.

- ◆ **Improving Collaboration and Information Sharing:** Business processes designed through a collaborative interface mean Information Technology can integrate its processes with the business-side logic that drives day-to-day operations.

Question 5

Discuss different types of servers based on the services they provide.

Answer

There are different types of servers based on the nature of service they provide. Some of them are given as follows:

- ◆ **File server:** This is a computer and storage device dedicated to storing files. Any user on the network can store files on the server.
- ◆ **Print server:** This is a computer that manages one or more printers.
- ◆ **Network server:** This is a computer that manages network traffic.
- ◆ **Database server:** This is a computer system that processes database queries.
- ◆ **Application Server:** This is a program that handles all application operations between users and an enterprise's backend business applications or databases.
- ◆ **Web Server:** Web server is a computer that delivers (serves up) web pages. Every web server has an IP address and possibly a domain name. For example, if we enter the URL <http://www.icai.org> in our browser, this sends a request to the Web server whose domain name is icai.org. The server then fetches the named home page and sends it to our browser. Any computer can be turned into a Web server by installing server software and connecting the machine to the Internet.
- ◆ **Mail Server:** Mail server moves and stores mail over corporate networks.

Question 6

What is Cloud Computing? Describe any three types of clouds in cloud computing environment.

Or

What are the different types of clouds in a Cloud computing environment?

Answer

Cloud Computing: Cloud computing is the use of various services, such as software development platforms, servers, storage, and software, over the Internet, often referred to as the "Cloud."

The Cloud Computing environment can consist of multiple types of clouds based on their deployment and usage. They are **Public Cloud**, **Private/Internal Cloud**, **Community Cloud** and **Hybrid Cloud**.

- ◆ **Public Clouds:** The public cloud is made available to the general public or a large industry group. They are administrated by third parties or vendors over the Internet, and services

2.13 Information Technology

are offered on pay-per-use basis. It is widely used in the development, deployment and management of enterprise applications, at affordable costs; and allows organizations to deliver highly scalable and reliable applications rapidly and at more affordable costs.

- ◆ **Private/Internal Clouds:** This cloud computing environment resides within the boundaries of an organization and is used exclusively for the organization's benefits. They are built primarily by IT departments within enterprises who seek to optimize utilization of infrastructure resources within the enterprise by provisioning the infrastructure with applications using the concepts of grid and virtualization. The Private Cloud enables an enterprise to manage the infrastructure and have more control.
- ◆ **Community Clouds:** This is the sharing of computing infrastructure in between organizations of the same community. For example, all Government organizations within India may share computing infrastructure on the cloud to manage data. The risk is that data may be stored with the data of competitors.
- ◆ **Hybrid Clouds:** It is a composition of two or more clouds (Private, Community or Public) and is maintained by both internal and external providers. Though they maintain their unique identity, they are bound together by standardized data and application portability. With a hybrid cloud, organizations might run non-core applications in a public cloud, while maintaining core applications and sensitive data in-house in a private cloud.

Question 7

Discuss Cloud Computing architecture.

Answer

Cloud Computing architecture refers to the components and subcomponents that typically consist of a front end platform (fat client, thin client, mobile device), back end platform (servers, storage), a cloud based delivery, and a network (Internet, Intranet, Intercloud). Cloud architecture typically involves multiple cloud components communicating with each other over a tight or loose coupling of cloud resources, services, middleware, and software components.

A cloud computing architecture consists of two parts - **Front End** and a **Back End** that connect to each other through a network, usually the Internet. The front end is the side the computer user or client, sees. The back end is the "cloud" section of the system.

- ◆ **Front End:** The front end of the cloud computing system comprises of the client's devices (or it may be a computer network) and some applications are needed for accessing the cloud computing system. All the cloud computing systems do not give the same interface to users. For example - Web services like electronic mail programs use some existing web browsers such as Firefox, Microsoft's Internet Explorer or Apple's Safari. Other types of systems have some unique applications which provide network access to its clients.
- ◆ **Back End:** Back end refers to some physical peripherals. In cloud computing, the back end is cloud itself which may encompass various computer machines, data storage systems and servers. Groups of these clouds make a whole cloud computing system.

Theoretically, a cloud computing system can include practically any type of web application program such as video games to applications for data processing, software development and entertainment residing on its individual dedicated server for services. There are some set of rules, generally called as **Protocols** which are followed by this server and it uses a special type of software termed as **Middleware** that allow computers that are connected on networks to communicate with each other. If any cloud computing service provider has many customers, then there's likely to be very high demand for huge storage space. Many companies that are service providers need hundreds of storage devices.

Question 8

Discuss Service models of Cloud Computing.

Answer

Service Models of Cloud Computing are as follows:

- ◆ **Infrastructure as a Service (IaaS):** It is the foundation of cloud services that provides clients with access to server hardware, storage, bandwidth and other fundamental computing resources. The service is typically paid for on a usage basis and may also include dynamic scaling so that if the customer needs more resources than expected, s/he can get them on the fly (probably to a given limit). It provides access to shared resources on need basis, without revealing details like location and hardware to clients.
- ◆ **Software as a Service (SaaS):** It includes a complete software offering on the cloud. Users can access a software application hosted by the cloud vendor on pay-per-use basis. SaaS is a model of software deployment where an application is hosted as a service provided to customers across the Internet by removing the need to install and run an application on a user's own computer. SaaS can alleviate the burden of software maintenance and support but users relinquish control over software versions and requirements.
- ◆ **Platform as a Service (PaaS):** It provides clients with access to the basic operating software and optional services to develop and use software applications (e.g. database access and payment service) without the need to buy and manage the underlying computing infrastructure. For example, Google App Engine allows clients to run their web applications (i.e. software that can be accessed using a web browser such as Internet Explorer over the internet) on Google's infrastructure.
- ◆ **Network as a Service (NaaS):** It is a category of cloud services where the capability provided to the cloud service user is to use network/transport connecting services. NaaS involves optimization of resource allocation by considering network and computing resources as a whole. Some of the examples are: Virtual Private Network, Mobile Network Virtualization etc.
- ◆ **Communication as a Service (CaaS):** CaaS is an outsourced enterprise communication solution that can be leased from a single vendor. The CaaS vendor is responsible for all hardware and software management and offers guaranteed Quality of Service (QoS). It

2.15 Information Technology

allows businesses to selectively deploy communication devices and modes on a pay-as-you-go, as-needed basis. This approach eliminates the large capital investments. Examples are: Voice over IP (VoIP), Instant Messaging (IM), Collaboration and Videoconferencing application using fixed and mobile devices.

Question 9

What is Mobile Computing? Discuss its components.

Answer

Mobile Computing: Mobile Computing is the use of portable computing devices (such as laptop and handheld computers) in conjunction with mobile communication technologies to enable users to access the Internet and data on their home or work computers from anywhere in the world. Mobile computing is enabled by use of mobile devices (portable and hand held computing devices) such as PDA, laptops, mobile phones, MP3 players, digital cameras, tablet PC and Palmtops on a wireless network.

Mobile computing involves **Mobile Communication, Mobile Hardware and Mobile Software;** which are discussed as follows:

- ◆ **Mobile Communication:** Mobile Communication refers to the infrastructure put in place to ensure that seamless and reliable communication goes on. These would include devices such as Protocols, Services, Bandwidth and Portals necessary to facilitate and support the stated services. The data format is also defined at this stage. The signals are carried over the air to intended devices that are capable of receiving and sending similar kind of signals. It will incorporate all aspects of wireless communication.
- ◆ **Mobile Hardware:** Mobile Hardware includes mobile devices or device components that receive or access the service of mobility. They would range from Portable laptops, Smart phones, Tablet PC's to Personal Digital Assistants. These devices will have receptors that are capable of sensing and receiving signals. These devices are configured to operate in full-duplex, whereby they are capable of sending and receiving signals at the same time.
- ◆ **Mobile Software:** Mobile Software is the actual program that runs on the mobile hardware. It deals with the characteristics and requirements of mobile applications. This is the engine of that mobile device. In other terms, it is the operating system of that appliance. It is the essential component that makes the mobile device operates.

Question 10

What is a Database Model? Discuss its various types.

Answer

A Database Model is a type of data model that determines the logical structure of a database and fundamentally determines in which manner data can be stored, organized and manipulated. Some prominent database models are as follows:

- A. Hierarchical Database Model:** In a hierarchical database model, records are logically organized into a hierarchy of relationships. A hierarchically structured database is arranged logically in an inverted tree pattern.

All records in hierarchy are called nodes. The top parent record in the hierarchy is called the **root record**. Records that “own” other records are called **parent records**. Each node is related to the others in a parent-child relationship. Each parent record may have one or more child records, but no child record may have more than one parent record.

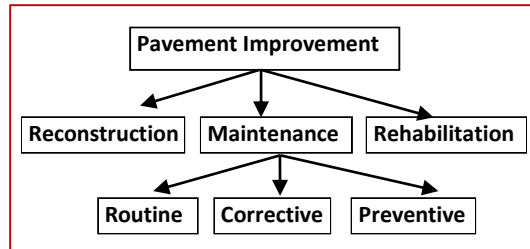

Thus, the hierarchical data structure implements one-to-one and one-to-many relationships. (Refer the fig.)

- B. Network Database Model:** The network model is a variation on the hierarchical model such that it is built on the concept of multiple branches (lower-level structures) emanating from one or more nodes (higher-level structures) and that branch may be connected to multiple nodes. The network model is able to represent redundancy in data more efficiently than in the hierarchical model. The network model also permits a record to be a member of more than one set at one time that allows the network model to implement the many-to-one and the many-to-many relationship types.

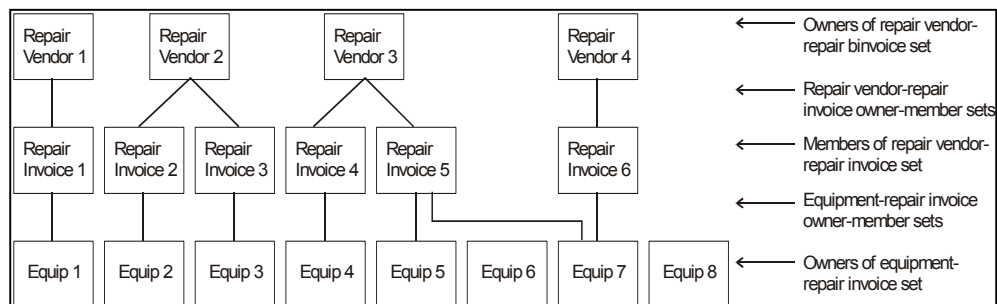

- C. Relational Database Model:** A relational database allows the definition of data and their structures, storage and retrieval operations and integrity constraints that can be organized in a table structure. A table is a collection of records and each record in a table contains the same fields. Three key terms are used extensively in relational database models: **Relations, Attributes** and **Domains**. A relation is a table with columns and rows. The named columns of the relation are called **attributes**, and the domain is the set of values the attributes can take.

A relational database contains multiple tables, with at least similar value occurring in two different records (belonging to the same table or to different tables) that implies a relationship among those two records. Tables can also have a designated single attribute

or a set of attributes that can act as a "key" which can be used to uniquely identify each record in the table. A key that can be used to uniquely identify a row in a table is called a **Primary key**. Any column can be a key, or multiple columns can be grouped together into a **Compound key**.

- D. **Object Oriented Data Base Model (OODBMS):** It is based on the concept that the world can be modeled in terms of objects and their interactions. An Object-oriented database provides a mechanism to store complex data such as images, audio and video, etc. An OODBMS helps programmers make objects created in a programming language behave as a database object. Object-oriented programming is based on a series of working objects. Each object is an independently functioning application or program, assigned with a specific task or role to perform. An OODBMS is a relational database designed to manage these independent programs, using the data produced to quickly respond to requests for information by a larger application.

Question 11

What is an Operating System? Discuss various activities it performs.

Answer

An **Operating System (OS)** is a set of computer programs that manages computer hardware resources and acts as an interface with computer applications programs. The operating system is a vital component of the system software in a computer system. Application programs usually require an operating system to function that provides a convenient environment to users for executing their programs. Computer hardware with operating system can thus be viewed as an extended machine which is more powerful and easy to use. Some prominent Operating systems used nowadays are Windows 7, Windows 8, Linux, UNIX, etc.

A variety of activities are executed by Operating systems which include:

- ◆ **Performing hardware functions:** Application programs to perform tasks must obtain input from keyboards, retrieve data from disk & display output on monitors. Achieving all this is facilitated by operating system that acts as an intermediary between the application program and the hardware.
- ◆ **User Interfaces:** An important function of any operating system is to provide user interface. DOS has a **Command based User Interface (UI)** i.e. text commands were given to computer to execute any command, whereas Windows has **Graphic User Interface (GUI)** which uses icons & menus.
- ◆ **Hardware Independence:** Every computer could have different specifications and configurations of hardware. Operating system provides **Application Program Interfaces (API)** which can be used by application developers to create application software, thus obviating the need to understand the inner workings of OS and hardware. Thus, OS gives us hardware independence.
- ◆ **Memory Management:** Memory Management features of Operating System control how memory is accessed and maximizes available memory & storage. Operating systems also

provides Virtual Memory by carving an area of hard disk to supplement the functional memory capacity of RAM.

- ◆ **Task Management:** Task Management feature of Operating system helps in allocating resources to make optimum utilization of resources. This facilitates a user to work with more than one application at a time i.e. multitasking and allows more than one user to use the system i.e. timesharing.
- ◆ **Networking Capability:** Operating systems can provide systems with features & capabilities to help connect computer networks. Like Linux & Windows 8 give us an excellent capability to connect to internet.
- ◆ **Logical Access Security:** Operating systems provide logical security by establishing a procedure for identification & authentication using a User ID and Password. It can log the user access thereby providing security control.
- ◆ **File Management:** The Operating System keeps a track of where each file is stored and who can access it, based on which it provides the file retrieval.

Question 12

What is CPU? What are the three functional units of a Central Processing Unit (CPU)?

Answer

The Central Processing Unit (CPU or microprocessor) is the actual hardware that interprets and executes the program (software) instructions and coordinates how all the other hardware devices work together. The CPU is built on a small flake of silicon and can contain the equivalent of several million transistors. We can think of transistors as switches which could be “ON” or “OFF” i.e., taking a value of 1 or 0. The processor or CPU is like the brain of the computer. The main function of CPU is to execute programs stored in memory. It consists of three functional units:

- ◆ **Control Unit (CU):** CU controls the flow of data and instruction to and from memory, interprets the instruction and controls which tasks to execute and when.
- ◆ **Arithmetic and Logical Unit (ALU):** Performs arithmetic operations such as addition, subtraction, multiplication, and logical comparison of numbers: Equal to, Greater than, Less than, etc.
- ◆ **Registers:** These are high speed memory units within CPU for storing small amount of data (mostly 32 or 64 bits). Registers could be:
 - **Accumulators:** They can keep running totals of arithmetic values.
 - **Address Registers:** They can store memory addresses which tell the CPU as to where in the memory an instruction is located.
 - **Storage Registers:** They can temporarily store data that is being sent to or coming from the system memory.
 - **Miscellaneous:** These are used for several functions for general purpose.

Question 13

Discuss Information System Life Cycle.

Answer

Information System Life Cycle is commonly referred as **Software/System Development Life Cycle (SDLC)** which is a methodology used to describe the process of building information systems. SDLC framework provides a sequence of activities for system designers and developers to follow. It consists of a set of steps or phases in which each phase of the SDLC uses the results of the previous one. Various phases for developing an Information System are given as follows:

Phase 1: System Investigation: This phase examines that 'What is the problem and is it worth solving'? A feasibility study is done under the dimensions – Technical, Economical, Legal, Operational etc.

Phase 2: System Analysis: This phase examines that 'What must the Information System do to solve the problem'? System analyst would be gathering details about the current system and will involve interviewing staff; examining current business; sending out questionnaires and observation of current procedures.

The Systems Analyst will examine data and information flows in the enterprise using data flow diagrams; establish what the proposed system will do (not how it will do it); analyze costs and benefits; outline system implementation options. (For example: in-house or using consultants); consider possible hardware configurations; and make recommendations.

Phase 3: System Designing: This phase examines that 'How will the Information System do what it must do to obtain the solution to the problem'? This phase specifies the technical aspects of a proposed system in terms of Hardware platform; Software; Outputs; Inputs; User interface; Modular design; Test plan; Conversion plan and Documentation.

Phase 4: System Implementation: This phase examines that 'How will the solution be put into effect'? This phase involves coding and testing of the system; acquisition of hardware and software; and either installation of the new system or conversion of the old system to the new one.

Phase 5: System Maintenance and Review: This phase evaluates results of solution and modifies the system to meet the changing needs. Post implementation review would be done to address Programming amendments; Adjustment of clerical procedures; Modification of Reports, and Request for new programs.

Question 14

Differentiate between the following:

- (a) *Random Access Memory and Read Only Memory*
- (b) *Hierarchical Database Model and Network Database Model*
- (c) *Complex Instruction Set Computer (CISC) and Reduced Instruction Set Computer (RISC)*

Answer

- (a) The differences between Random Access Memory (RAM) and Read Only Memory (ROM) are given below:

Random Access Memory (RAM)	Read Only Memory (ROM)
RAM is a volatile memory and when the computer is turned off, RAM loses its data. When the computer is turned on again, operating system and other files are once again loaded into RAM usually from the hard disk.	Unlike RAM, ROM is non-volatile. The contents of ROM remain even after the computer is switched off.
This is Read Write memory wherein information can be read as well as modified.	Originally, the ROM used to be read-only; however, the new versions of ROM allow limited rewriting making it possible to upgrade firmware such as the BIOS by using installation software.

- (b) The differences between Hierarchical Database Model and Network Database Model are given below:

Hierarchical Database Model	Network Database Model
The hierarchical model permits a record to be a member of only one set at one time.	Unlike the hierarchical mode, the network model permits a record to be a member of more than one set at one time.
The hierarchical data structure implements one-to-one and one-to-many relationships.	The network model allows us to represent one-to-one, one-to-many and many-to-many relationships.
Each parent record may have one or more child records, but no child record may have more than one parent record.	Each parent record may have one or more child records, and even a child record may have more than one parent record.
The hierarchical model does not represent redundancy in data efficiently.	The network model can represent redundancy in data more efficiently than in the hierarchical model.
The hierarchical data structures require specific entrance points to find records in a hierarchy.	The network data structures can be entered and traversed more flexibly.

- (c) **Complex Instruction Set Computer (CISC):** If the Control Unit contains several micro-electronic circuitries to generate a set of control signals and each micro-circuitry is activated by a micro-code, this design approach is called CISC design. Examples of CISC processors are: Intel 386, 486, Pentium, Pentium Pro, Pentium II, Pentium III processors etc. CISC chips have a large, variable length and complex instructions and generally make

2.21 Information Technology

use of complex addressing modes. Different machine programs can be executed on CISC machine. Since CISC processors possess so many processing features, the job of machine language programmers becomes easier. But at the same time, they are complex as well as expensive to produce. Now-a-days, most of the personal computers use CISC processors.

Reduced Instruction Set Computer (RISC): To execute each instruction, if there is separate electronic circuitry in the control unit, which produces all the necessary signals, this approach of the design of the control section of the processor is called RISC design. It is also called hard-wired approach. Examples of RISC processors: IBM RS6000, MC88100 processors etc. RISC processors use a small and limited number of instructions and mostly use hardwired control unit. These consume less power and are having high performance. RISC processors use simple addressing modes and RISC instruction is of uniform fixed length. Since RISC processors have a small instruction set, they place extra demand on programmers who must consider how to implement complex computations by combining simple instructions. However, RISC processors are faster, less complex and less expensive than CISC processors because of their simpler design.

Question 15

What is mobile computing? What are the three major concerns related to mobile computing?

Answer

Mobile Computing: Mobile Computing is the use of portable computing devices (such as laptop and handheld computers) in conjunction with mobile communication technologies to enable users to access the Internet and data on their home or work computers from anywhere in the world. Mobile computing is enabled by use of mobile devices (portable and hand held computing devices) such as PDA, laptops, mobile phones, MP3 players, digital cameras, tablet PC and Palmtops on a wireless network.

Major concerns relating to mobile computing are given as follows:

- Mobile computing has its fair share of security concerns as any other technology.
- Dangers of misrepresentation - Another problem plaguing mobile computing are credential verification.
- Power consumption - When a power outlet or portable generator is not available, mobile computers must rely entirely on battery power.
- Potential health hazards

Question 16

Name the various phases of System Development Life Cycle (SDLC) in the logically correct order.

Answer

The various phases of System Development Life Cycle (SDLC) are as follows:

- Phase 1: System Investigation
- Phase 2: System Analysis
- Phase 3: System Designing
- Phase 4: System Implementation
- Phase 5: System Maintenance and Review

Question 17

What is Server? Briefly explain any four types of servers based on the nature of service they provide.

Answer

Server: A server is a computer program running to serve the requests of other programs, the "clients". Servers are often dedicated, meaning that they perform no other tasks besides their server tasks. The clients either run on the same computer, or they connect through the network. Some of the different types of servers based on the nature of service they provide are as follows:

- **File server:** This is a computer and storage device dedicated to storing files. Any user on the network can store files on the server.
- **Print server:** This is a computer that manages one or more printers.
- **Network server:** This is a computer that manages network traffic.
- **Database server:** This is a computer system that processes database queries.
- **Application Server:** This is a program that handles all application operations between users and an enterprise's backend business applications or databases.
- **Web Server:** Web server has an IP address and possibly a domain name, and is the computer that delivers (serves up) web pages.
- **Mail Server:** Mail servers move and store mail over corporate networks.

Question 18

- Mention briefly the different types of application software.*
- What are the major advantages and disadvantages of DBMS?*

Answer

- (a) The different types of application software are as under:
- ◆ **Application Suite:** Has multiple applications bundled together. Related functions, features and user interfaces interact with each other. E.g. MS Office 2010 which has MS Word, MS Excel, MS Access, etc.
 - ◆ **Enterprise Software:** Addresses an enterprise's needs and data flow in a huge distributed environment. E.g. ERP Applications like SAP.
 - ◆ **Enterprise Infrastructure Software:** Provides capabilities required to support enterprise software systems. E.g. email servers, Security software.
 - ◆ **Information Worker Software:** Addresses individual needs required to manage and create information for individual projects within departments. E.g. Spreadsheets, CAAT (Computer Assisted Audit Tools) etc.
 - ◆ **Content Access Software:** Used to access contents and addresses a desire for published digital content and entertainment. E.g. Media Players, Adobe Digital etc.
 - ◆ **Educational Software:** Holds contents adopted for use by students. E.g. Examination Test CDs.
 - ◆ **Media Development Software:** Addresses individual needs to generate and print electronic media for others to consume. E.g. Desktop Publishing, Video Editing etc.
- (b) Major advantages of Database Management Systems (DBMS) are given as follows:
- ◆ **Permitting data sharing:** One of the principle advantages of a DBMS is that the same information can be made available to different users.
 - ◆ **Minimizing Data Redundancy:** In a DBMS duplication of information or redundancy is, if not eliminated, carefully controlled or reduced i.e. there is no need to repeat the same data repeatedly. Minimizing redundancy can therefore significantly reduce the cost of storing information on hard drives and other storage devices.
 - ◆ **Integrity can be maintained:** Data integrity is maintained by having accurate, consistent, and up-to-date data. Updates and changes to the data only must be made in one place in DBMS ensuring Integrity. The chances of making a mistake increase if the same data needs to be changed at several different places than making the change in one place.
 - ◆ **Program and file consistency:** Using a DBMS, file formats and programs are standardized. This makes the data files easier to maintain because the same rules and guidelines apply across all types of data. The level of consistency across files and programs also makes it easier to manage data when multiple programmers are involved.

- ◆ **User-friendly:** DBMS makes the data access and manipulation easier for the user. DBMS also reduce the reliance of users on computer experts to meet their data needs.
- ◆ **Improved security:** DBMSs allow multiple users to access the same data resources which could lead to risk to an enterprise if not controlled. Security constraints can be defined i.e. Rules can be built to give access to sensitive data. Some sources of information should be protected or secured and only viewed by select individuals. Using passwords, database management systems can be used to restrict data access to only those who should see it.
- ◆ **Achieving program/data independence:** In a DBMS data does not reside in applications but data bases program & data are independent of each other.
- ◆ **Faster application development:** In the case of deployment of DBMS, application development becomes fast. The data is already therein databases, application developer has to think of only the logic required to retrieve the data in the way a user needs.

Major disadvantages of DBMS are as under:

- ◆ **Cost:** Implementing a DBMS system can be expensive and time-consuming, especially in large enterprises. Training requirements alone can be quite costly.
- ◆ **Security:** Even with safeguards in place, it may be possible for some unauthorized users to access the database. If one gets access to database, then it could be an all or nothing proposition.

Question 19

Describe the following Recent technologies in the field of IT:

- (i) iPad
- (ii) Ultra Mobile PC (UMPC)
- (iii) I-pod

Answer

- (i) **iPad:** The iPad runs a version of iOS. iOS is designed for finger based use and has none of the tiny features which required a stylus on earlier tablets. Apple introduced responsive multi touch gestures, like moving two fingers apart to zoom in. iOS uses less power, and so gives better battery life than the Intel devices used by Windows tablets.
- (ii) **Ultra Mobile PC (UMPC):** An Ultra-Mobile PC is a small form factor version of a pen computer, a class of laptop whose specifications were launched by Microsoft and Intel in spring 2006. UMPCs are smaller than subnotebooks, have a TFT display measuring (diagonally) about 12.7 to 17.8 cm (5 to 7 inch screen), are operated like tablet PCs

using a touch screen or a stylus, and can also have a physical keyboard.

- (iii) ***iPod***: The iPod is a line of portable media players designed and marketed by Apple Inc. There are four current versions of the iPod: the ultra-compact iPod Shuffle, the compact iPod Nano, the touch screen iPod Touch, and the hard drive-based iPod Classic. Like other digital music players, iPods can serve as external data storage devices. Storage capacity varies by model, ranging from 2 GB for the iPod Shuffle to 160 GB for the iPod Classic.

Question 20

Write some Information Systems Control procedures covering the access safeguards over computer programs.

Answer

- (a) **Information Systems Control procedures covering the access safeguards over computer programs are as follows:**
- **Strategy and direction;**
 - **General Organization and Management;**
 - **Access to IT resources, including data and programs;**
 - **System development methodologies and change control;**
 - **Operation procedures;**
 - **System Programming and technical support functions;**
 - **Quality Assurance Procedures;**
 - **Physical Access Controls;**
 - **Business Continuity Planning (BCP) and Disaster Recovery Planning (DRP);**
 - **Network and Communication;**
 - **Database Administration; and**
 - **Protective and detective mechanisms against internal and external attacks.**

Exercise

1. *Discuss some of the benefits of using a Computer Network.*
2. *What are the Output devices? Discuss some of the examples of output devices.*
3. *What are the objectives of System Maintenance in SDLC?*
4. *Discuss some of the different parameters undertaken during Feasibility Study in SDLC.*
5. *Discuss some of the issues a computer network addresses to?*

6. *What are the major activities involved in the Conversion phase of System Implementation in SDLC?*
7. *Give some examples of business applications of Mobile computing?*
8. *Discuss different types of Application Software.*
9. *What are the advantages and disadvantages of the following:*
 - (a) *Application Software*
 - (b) *DBMS*

3

Telecommunication and Networks

3.1 Introduction

Telecommunication technology is moving towards open, internetworked digital networks for voice, data, video and multimedia whose primary goal is to promote easy and secure access by business professionals and consumers to the resources of the Internet, enterprise Intranets, and inter-organizational Extranets. The major generic components of any telecommunication network are Terminals, Telecommunication processors, Communication Channels, Computers, and Telecommunication Software. Basic types of telecommunication networks include WANs and LANs which are interconnected using client/server, network computing, peer-to-peer, and Internetworking technologies.

Telecommunication processors include modems, multiplexers, internetworked processors, and various devices to help interconnect and enhance the capacity and efficiency of telecommunication channels such as twisted-pair wiring, coaxial cables, fiber-optic cables, terrestrial microwave, communications satellites, cellular and PCS systems, wireless LANs, and other wireless technologies.

3.2 Networking an Enterprise

The Internet and Internet-like networks inside the enterprise are called **Intranets**; between an enterprise and its trading partners are called **Extranets**. Managers, teams, end users, and workgroups use telecommunications networks to electronically exchange data and information anywhere in the world with other end users, customers, suppliers, and business partners.

3.3 Trends in Telecommunication

Major trends that are occurring in the field of telecommunication are as follows:

Trend	Objective
Industry Trends	Towards more competitive vendors, carriers, alliances and network services, accelerated by deregulation and the growth of Internet and WWW.
Technology Trends	Towards extensive use of Internet, digital fiber-optic, and wireless technologies to create high-speed local and global internetworks for voice, data, images, audio, and video-communications.
Business Application Trends	Towards the pervasive use of the Internet, enterprise intranets, and inter-organizational extranets to support electronic business and commerce, enterprise collaboration, and strategic advantage in local and global markets.

3.4 The Business Value of Telecommunications

Information technology, especially in telecommunication-based business applications, helps company overcome barriers to business success. The strategic capabilities of telecommunications and other information technologies include overcoming geographic, time, cost and structural barriers.

3.5 Telecommunication Network

A **Telecommunication Network** is a collection of terminal nodes, links and any intermediate nodes which are connected so as to enable telecommunication between the terminals.

3.5.1 Need and Scope of Networks

Telecommunication network allows file and resource sharing; remotely accessing of data and information via Internet; simultaneous access to the shared databases; implementation of fault tolerance over a network; providing access to the Internet for transferring the document and to access the resources.

3.5.2 Telecommunication Network Model

A simple conceptual model of a telecommunication network consists of five basic categories of components:

Terminals	Any input or output device such as Video Terminals, Microcomputers, Telephones, Office Equipment, Telephone and Transaction Terminals that are used to transmit or receive data.
Telecommunication Processors	Support data transmission and reception between terminals and computers by providing a variety of control and support functions. They include Network Interface Card, MODEM, Multiplexer and Internetworked Processors (such as switch, router, hub, bridge, repeater and gateway).
Telecommunication Media / Channels	These connect the message source with the message receiver by means of Guided/Bound Media (Twisted Pair, Coaxial cable and Fiber optics) or Unguided/Unbound media (Terrestrial Microwaves, Radio waves, Micro Waves, Infrared Waves and Communication Satellites).
Computers	Computers of all sizes and types connected through media to perform their communication assignments and include Host Computers, Front-End Processors and Network Servers.
Telecommunication Control Software	Consists of programs that control and manage the functions of telecommunication networks and include Telecommunication Monitors, Network Operating Systems, Network Management Components and Communication Packages.

3.6 Classification of Telecommunication Networks

On the basis of different factors, telecommunication networks can be classified as follows:

- **Area Coverage Based:** LAN, MAN and WAN.
- **Functional Based:** Client-Server, Peer-to-Peer and Multi-Tier.
- **Ownership Based:** Public Network, Private Network and Virtual Private Network (VPN).

3.6.1 Area Coverage Based Classification

Local Area Network (LAN)	Metropolitan Area Network (MAN)	Wide Area Network (WAN)
It is a group of computers and other network devices which are connected together. These cover manufacturing plant, classrooms, buildings etc.	It is a larger network of computers and other network devices which are connected together and usually spans several buildings of large geographical area. Cable television is an example of MAN.	It is a group of computers and other network devices which are connected together and is not restricted to a geographical location. Internet is a WAN.
All the devices that are part of LAN are within a building or multiple building spanned over limited space.	All the devices that are part of MAN are span across buildings or small town.	All the devices that are part of WAN have no geographical boundaries.
LAN has very high speed mainly due to proximity of computer and network devices.	MAN has lower speed as compared to LAN.	WAN speed varies based on geographical location of the servers. WAN connects several LANs.
LAN connection speeds can be 10Mbps; 100Mbps or 1000Mbps also.	MAN connection speeds can be 10Mbps or 100Mbps.	WAN connection speeds can be 10 Mbps or 100 Mbps.
LAN uses Guided Media.	MAN uses both Guided Media and Unguided media.	WAN uses Guided Media and Unguided media both.

3.6.2 Functional Based Classification	
Client Server Network (C/S)	It is a computer network in which one centralized powerful computer (called Server) is connected to many less powerful PCs or workstations (called Clients). The clients run programs and access data that are stored on the server. Example – WWW/e-Mail.
Peer-to-Peer Network (P2P)	It is a network which is created with two or more PCs connected together and share resources without going through a separate server computer. Example – Napster, Freenet etc.
Multi-Tier Architecture	A tier is a distinct part of hardware or software.
◆ Single Tier Systems/One-Tier Architecture	Consists of a single computer that contains a database and a front-end (GUI) to access the database. There is one computer which stores all of the company's data on a single database.
◆ Two Tier Systems/Two Tier Architecture	Consists of a client and a server. The database is stored on the server, and the interface used to access the database is installed on the client.
◆ n-Tier Architecture (Three tier)	It is a client-server architecture in which the functional process logic, data access, computer data storage and user interface are developed and maintained as independent modules on separate platforms.
3.6.3 Ownership Based Classification	
Public Data Network	It is defined as a network shared and accessed by users not belonging to a single organization. Example – Internet.
Private Data Network	It provides businesses, government agencies and organizations of all sizes as a dedicated network to continuously receive and transmit data critical to both the daily operations and mission critical needs of an organization.
Virtual Private Network	It is a private network that uses a public network (usually the Internet) to connect remote sites or users together.
3.7 Network Computing	
The network computing concept considers networks as the central computing resource of any computing environment. Features of network computing model include User Interface; System and Application Software; Databases and Database Management. Two basic network computing models are as follows:	

3.5 Information Technology

- ◆ **Centralized Computing:** Centralized computing is computing done at a central location, using terminals that are attached to a central computer. The computer itself may control all the peripherals directly (if they are physically connected to the central computer) or they may be attached via a terminal server.
- ◆ **Decentralized Computing:** Decentralized computing is the allocation of resources, both hardware and software, to each individual workstation, or office location which are capable of running independently of each other. Decentralized systems enable file sharing and all computers can share peripherals such as printers and scanners as well as modems, allowing all the computers in the network to connect to the Internet.

3.7.1 Network Topology

The term 'Topology' defines the physical or logical arrangement of links in a network.

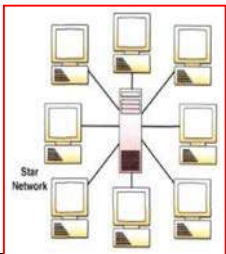
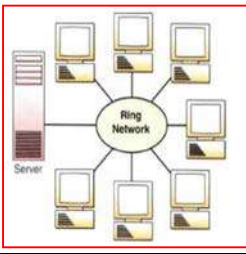
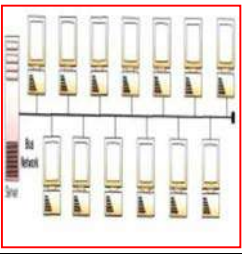
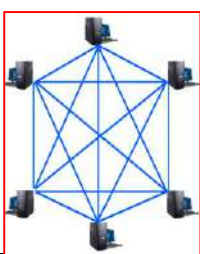
Star Network	Ring Network	Bus Network	Mesh Network
The central unit (server) in the network acts as the traffic controller among all the other computers tied to it.	Local computer processors are tied together sequentially in a ring with each device being connected to two other devices under a decentralized approach.	A single length of wire, cable, or optical fiber connects a number of computers.	Each node is connected by a dedicated point to point link to every node.
			
A node failure does not bring down the entire network. Failure of server affects the whole network.	Failure of one computer on the network can affect the whole network.	If one of the microcomputer fails, it will not affect the entire network.	If one of the node fails, the network traffic can be redirected to another node.
New nodes can be added easily without affecting rest of the network.	Ring topology is considered to be inefficient as data can only travel in one route to reach its destination, and the data usually travels to several points prior to reaching its intended destination.	It is easy to install, easily extendable and inexpensive.	A mesh topology is the best choice when we require fault tolerance, however, it is very difficult to setup and maintain.

3.7.2 Digital Data Transmission

```

graph TD
    DT[Data Transmission] --> P[Parallel]
    DT --> S[Serial]
    S --> AS[Asynchronous]
    S --> SYN[Synchronous]
    
```

A. Serial versus Parallel Mode: Depends on number of bits sent simultaneously.

- **Serial Transmission** – Data bits are transmitted serially one after another over a single wire, and thus relatively slower.
- **Parallel Transmission** – Data bits are transmitted simultaneously over eight different wires and thus relatively faster.

The two ways of transmitting serial binary data – Asynchronous and Synchronous

- **Asynchronous Transmission** – In this, each character is sent at irregular intervals in time as in the case of characters entered at the keyboard in real time. So, the sender provides a synchronization signal to the receiver before starting the transfer of each message.
- **Synchronous Transmission** – In this, the transmitter and receiver are paced by the same clock. The receiver continuously receives (even when no bits are transmitted) the information at the same rate the transmitter sends it.

B. Transmission Mode: The direction of signal flow – Simplex, Half-Duplex and Full Duplex Connection.

Simplex Connection	Half-Duplex Connection	Full Duplex Connection
Data flows in only one direction.	Data flows in one direction or the other, but not both at the same time.	Data flows in both directions simultaneously.
Example – Data from user's computer to the printer or from the mouse to user's computer.	Example – Walkie-Talkie.	Example – Mobile Phones.

C. Transmission Techniques – Based on the techniques used to transfer data, communication networks can be categorized into **Broadcast** and **Switched networks**.

- **Broadcast Networks** - In Broadcast networks, data transmitted by one node is received by many, sometimes all, of the other nodes. This refers to a method of transferring a message to all recipients simultaneously. For example – a corporation or other voluntary association that provides live television or recorded content such as movies, newscasts, sports, public affairs programming, and other television programs for broadcast over a group of radio stations or television stations.
- **Switched Networks** - In switched-communication networks, however, the data transferred from source to destination is routed through the switch nodes. The way in which the nodes switch data from one link to another, as it is transmitted from source to destination node, is referred to as a switching technique. Three common switching techniques are **Circuit Switching, Packet Switching, and Message Switching**.

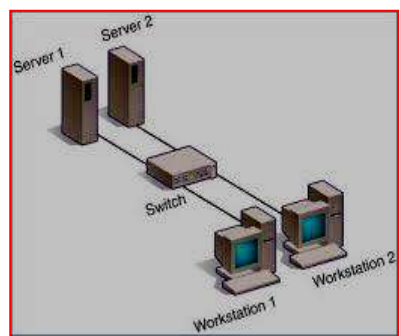
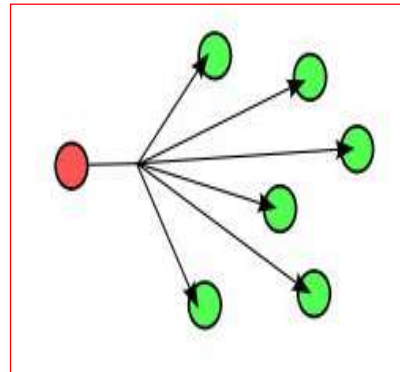

3.7.3 Network Architectures and Protocols

Network Architecture: Network Architecture refers to the layout of the network, consisting of the hardware, software, connectivity, communication protocols and mode of transmission, such as wired or wireless.

Protocol: A protocol is the formal set of rules for communicating, including rules for timing of message exchanges, the type of electrical connection used by the communications devices, error detection techniques, means of gaining access to communications channels, and so on. A protocol defines the following three aspects of digital communication.

- Syntax:** The format of data being exchanged, character set used, type of error correction used, type of encoding scheme (e.g., signal levels) being used.
- Semantics:** Type and order of messages used to ensure reliable and error free information transfer.
- Timing:** Defines data rate selection and correct timing for various events during data transfer.

Relationship between layers of TCP/IP and OSI Model is shown below:

TCP/IP	The OSI Model	Functions
Application or Process Layer	Application Layer	Provides communications services for end user applications
	Presentation Layer	Provides appropriate data transmission formats and codes
	Session Layer	Supports the accomplishment of telecommunication sessions
Host-to-Host Transport Layer	Transport Layer	Supports the organization and transfer of data between nodes in the network
Internet Protocol (IP)	Network Layer	Provides appropriate routing by establishing connections among network links
Network Interface	Data Link Layer	Supports error-free organization and transmission of data in the network
Physical Layer	Physical Layer	Provides physical transmission of data on the telecommunication media in the network

3.8 Network Risks, Controls and Security

The basic objective for providing network security is to safeguard assets and to ensure and maintain the data integrity. There are two types of systems security – **Physical Security** and **Logical Security**.

- ◆ A **Physical Security** is implemented to protect the physical systems assets of an organization like the personnel, hardware, facilities, supplies and documentation.
- ◆ A **Logical Security** is intended to control malicious and non-malicious threats to physical security and malicious threats to logical security itself.

3.8.1 Threats and Vulnerabilities

Threat: In context of computer networks, a **Threat** is a possible danger that can disrupt the operation, functioning, integrity, or availability of a network or system. Network security threats can be categorized into four broad themes – **Unstructured threats, Structured threats, External threats** and **Internal threats**.

Vulnerability: **Vulnerability** is an inherent weakness in the design, configuration, or implementation of a network or system that renders it susceptible to a threat. Software Bugs, Timing Windows, Insecure default configurations, trusting untrustworthy information and end-users are some of the facts responsible for occurrence of vulnerabilities in the software.

3.8.2 Level of Security

A security program is a series of ongoing, regular and periodic review of controls exercised to ensure safeguarding of assets and maintenance of data integrity and involve certain steps.

3.8.3 Network Security

Network Security Protocols are primarily designed to prevent any unauthorized user, application, service or device from accessing network data by implementing cryptography and encryption techniques. Network security protocols generally implement Digital Signatures, Cryptography and Encryption Techniques.

(a) **Privacy:** This means that the sender and the receiver expect confidentiality. The transmitted message should make sense to only the intended receiver and the message should be unintelligible to unauthorized users and is achieved by cryptography and encryption techniques.

◆ **Cryptography:** "Crypto" stands for "hidden, secret", and "graphy" denotes "a process or form of drawing, writing, representing, recording, describing, etc., or an art or science concerned with such a process."

◆ **Encryption:** In Cryptography, encryption is the process of encoding messages (or information) in such a way that eavesdroppers or hackers cannot read it, but only authorized parties can. The two basic approaches to encryption are **Hardware encryption** and **Software encryption**.

(b) **Authentication:** This means that the receiver is sure of the sender's identity and that an imposter has not sent the message.

(c) **Integrity:** Ensures that the data must arrive at the receiver exactly as it was sent.

(d) **Non-Repudiation:** Ensures that a receiver must be able to prove that a received message came from a specific sender and the sender must not be able to deny sending it.

3.8.4 Network Security Protocols

Some of the popular network security protocols include **Secure Shell (SSH)**, **Secure File Transfer Protocol (SFTP)**, **HyperText Transfer Protocol Secure (HTTPS)** and **Secure Socket Layer (SSL)** etc.

3.8.5 Network Security Techniques

Several tools/technologies are now available to protect information and systems against compromise, intrusion, or misuse. **Firewall**, **Intrusion Detection System (IDS)**, **Network Access Control**, **Anti – malware** and **site blocking** are some of them.

3.9 Network Administration and Management

In computer networks, **Network Management** refers to the activities, methods, procedures, and tools that pertain to the **Operation, Administration, Maintenance, and Provisioning** of networked systems. The common characteristics of network management are **FCAPS - Fault, Configuration, Accounting, Performance and Security**

3.10 The Internet Revolution

The Internet is the largest “network of networks” today, and the closest model we have to the information superhighway of tomorrow. Internet includes strategic capabilities that overcome geographic, time, cost and structural barriers along with their business applications.

3.10.1 Networks and the Internet

A computer network is two or more computers linked together to share information and/or resources. There are several types of computers networks, but the types most important to the topic of accounting information systems are Local Area Network (LAN), the Internet, Extranet, and Intranet.

3.10.2 Internet Architecture

- (a) To join the Internet, the computer is connected to an Internet Service Provider (ISP) from whom the user purchases Internet access or connectivity.
- (b) ISP’s architecture is made up of long-distance transmission lines that interconnect routers at Point of Presence (POP) in different cities that the ISPs serve. This equipment is called the backbone of the ISP.
- (c) ISPs connect their networks to exchange traffic at IXPs (Internet eXchange Points). The connected ISPs are said to peer with each other.
- (d) The path a packet takes through Internet depends on the peering choices of the ISPs.

3.10.3 Internet Applications

Email, e-Commerce, electronic discussion forums, real-time conversations, search engines, downloading software and information files are some of the Internet applications.

3.10.4 Business Use of the Internet

Some of the business uses of the Internet include providing customer and vendor support, marketing, sales, and customer service applications, growth of cross-functional business applications, collaboration among business partners, e-commerce and attracting new customers with innovative marketing and products.

3.10.5 Intranet

An **Intranet** is a network inside an organization that uses Internet technologies such as web browsers and servers, TCP/IP network protocols. An Intranet is protected by security measures such as passwords, encryption, and firewalls, and thus can be accessed by authorized users through the Internet.

3.10.6 Extranets

Extranets are network links that use Internet technologies to interconnect the Intranet of a business with the Intranets of its customers, suppliers, or other business partners. Companies can use Extranets to establish direct private network links between themselves, or create private secure Internet links between them.

3.11 Information Technology

3.10.7 Information Systems and Telecommunication

Telecommunications give an organization the capability to move information rapidly between distant locations and to provide the ability for the employees, customers, and suppliers to collaborate from anywhere, combined with the capability to bring processing power to the point of the application.

3.11 Electronic Commerce

Electronic Commerce refers to the use of technology to enhance the processing of commercial transactions between a company, its customers and its business partners. It involves the automation of a variety of business-to-business and business-to-consumer transactions through reliable and secure connections.

3.11.1 Benefits of e-Commerce Application and Implementation

E-Commerce presents immense benefits to individual organizations, consumers, and society as a whole. Reduction in advertising costs, errors, time, and overhead cost to buyers, and reduction in time to complete business transactions are some of the major benefits of e-Commerce transactions.

3.11.2 Risks involved in e-Commerce

Problem of anonymity, repudiation of contract, lack of authenticity of transactions, data loss or theft or duplication, attack from hackers, denial of service are some of the risks that are associated with e-Commerce.

3.11.3 Types of e-Commerce

The general classes of e-Commerce applications are as follows:

- (a) **Business-to-Business (B2B) e-Commerce** – This refers to the exchange of services, information and/or products from one business to another.
- (b) **Business-to-Consumer (B2C) e-Commerce** - This is defined as the exchange of services, information and/or products from a business to a consumer, as opposed to between one business and another.
- (c) **Consumer-to-Business (C2B) e-Commerce** - Consumers directly contact with business vendors by posting their project work online so that the needy companies review it and contact the consumer directly with bid.
- (d) **Consumer-to-Consumer (C2C) e-Commerce** – It is an Internet-facilitated form of commerce that has existed for the span of history in the form of barter, flea markets, swap meets, yard sales and the like.
- (e) **Business-to-Government (B2G) e-Commerce** - This refers to the use of information and communication technologies to build and strengthen relationships between government and employees, citizens, businesses, non-profit organizations, and other government agencies.
- (f) **Business-to-Employee (B2E) e-Commerce** - This provides the means for a business to offer online products and services to its employees.

3.11.4 Key aspects to be considered in implementing e-Commerce

Successful implementation of e-Commerce requires involvement of key stakeholders and should ideally include representatives from accounting/ finance, internal audit, IT security, telecommunication, end users, system analysts, and legal.

3.12 Mobile Commerce

Mobile Commerce or m-Commerce is about the explosion of applications and services that are becoming accessible from Internet-enabled mobile devices. It is buying and selling of goods and services through wireless handheld devices such as cellular telephone and PDAs.

3.13 Electronic Fund Transfer

Electronic Funds Transfer (EFT) represents the way the business can receive direct deposit of all payments from the financial institution to the company bank account. Once the user “Signs Up”, money comes to him directly and sooner than ever before. Some examples of EFT systems in operation are Automated Teller Machines (ATMs), Point-of-Sale (PoS) Transactions, Preauthorized and Telephone Transfers.

Question 1

Define the following terms briefly:

- | | |
|----------------------------------|-----------------------------|
| (a) Network Interface Card (NIC) | (b) MODEM |
| (c) Multiplexer | (d) Internetwork Processors |
| (e) Switch | (f) Router |
| (g) Hub | (h) Bridge |
| (i) Repeater | (j) Gateway |
| (k) Server | (l) Protocol |

Answer

- (a) **Network Interface Card (NIC)** – Network Interface Card (NIC) is a computer hardware component that connects a computer to a computer network. It has additional memory for buffering incoming and outgoing data packets, thus improving the network throughput.
- (b) **MODEM** – A MODEM is a device that converts a digital computer signal into an analog telephone signal (i.e. it modulates the signal) and converts an analog telephone signal into a digital computer signal (i.e. it demodulates the signal) in a data communication system.
- (c) **Multiplexer** – A multiplexer is a communication processor that allows a single communication channel to carry simultaneous data transmissions from many terminals. A multiplexer merges the transmission of several terminals at one end of a communication channel while a similar unit separates the individual transmissions at the receiving end.

3.13 Information Technology

- (d) **Internetwork Processors** – Telecommunication networks are interconnected by special-purpose communication processors called internetwork processors such as switches, routers, hubs, bridges, repeaters and gateways.
- (e) **Switch** – Switch is a communication processor that makes connections between telecommunication circuits in a network so that a telecommunication message can reach its intended destination.
- (f) **Router** – Router is a communication processor that interconnects networks based on different rules or protocols, so that a telecommunication message can be routed to its destination.
- (g) **Hub** – Hub is a port-switching communication processor. This allows for the sharing of the network resources such as servers, LAN workstations, printers, etc.
- (h) **Bridge** – Bridge is a communication processor that connects number of Local Area Networks (LAN). It magnifies the data transmission signal while passing data from one LAN to another.
- (i) **Repeater** – Repeater is a communication processor that boosts or amplifies the signal before passing it to the next section of cable in a network.
- (j) **Gateway** – Gateway is a communication processor that connects networks and use different communication architectures.
- (k) **Server** – A server is one or more multi-user processors with shared memory providing computing, connectivity and the database services and the interfaces relevant to the business need.
- (l) **Protocol** – A protocol is the formal set of rules for communicating, including rules for timing of message exchanges, the type of electrical connection used by the communications devices, error detection techniques, means of gaining access to communications channels, and so on.

Question 2

Differentiate between the following:

- (a) *Guided Media and Unguided Media*
- (b) *Client Server Network and Peer-to-Peer Network*
- (c) *Serial Transmission and Parallel Transmission*
- (d) *Synchronous Transmission and Asynchronous Transmission*

Answer

- (a) The differences between Guided Media and Unguided Media are given below:

Guided Media	Unguided Media
Guided Media are those media that provide a conduit from one device to another.	Unguided Transmission Media consists of a means for the data signals to travel but nothing to guide them along a specific path.
Guided Transmission Media uses a "cabling" system that guides the data signals along a specific path.	It passes through a vacuum; it is independent of a physical pathway.
Example – Coaxial Cable, Twisted Pair, Fiber Optic Cable.	Example – Infrared Waves, Micro Waves, Radio Waves etc.

(b) The differences between Client Server Network and Peer-to-Peer Network are given below:

Client Server Network	Peer-to-Peer Network
A client computer typically communicates only with servers, not with other clients.	Every computer is equal and can communicate with any other computer on the network to which it has been granted access rights.
A central server handles all security and file transactions.	Each machine shares its own resources and handles its own security.
It is more expensive as it requires a central file server, server software and client licenses.	It is relatively less expensive as it does not require a dedicated machine, server software or special client licenses.
More secure.	Lesser secure as the network control is handed to the end-users.
Backup is centralized on the server; managed by network administrator. Backup by device and media only required at server.	Backup is decentralized; managed by users. Backup devices and media are required at each workstation.
The performance is relatively high as the server is dedicated and does not handle other tasks.	The performance is relatively low.
In case of failure of server, the whole network fails.	No single point of failure in the network.
C/S model relies on the power and stability of a single computer i.e. Server.	P2P gives each workstation equivalent capabilities and relies heavily on the power and bandwidth of each individual computer.
Example - Email, network printing, and the World Wide Web.	Example - Napster, Gnutella, Freenet, BitTorrent and Skype.

3.15 Information Technology

(c) The differences between Serial Transmission and Parallel Transmission are given below:

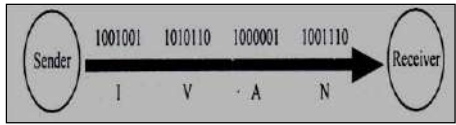
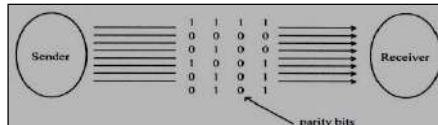
Serial Transmission	Parallel Transmission
In this, the data bits are transmitted serially one after another.	In this, the data bits are transmitted simultaneously.
Data is transmitted over a single wire and is thus relatively slower.	Data is transmitted over eight different wires and is thus relatively faster.
It is a cheaper mode of transferring data.	It is relatively expensive mode of transferring data.
	
It is useful for long distance data transmissions.	Not practical for long distance communications.

(d) The differences between Synchronous Transmission and Asynchronous Transmission are given below:

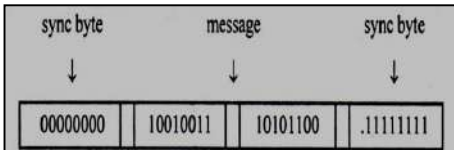
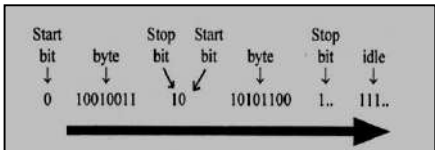
Synchronous Transmission	Asynchronous Transmission
Allows characters to be sent down the line without Start-Stop bits.	Each data word is accompanied with start and stop bits.
Transmission is faster as in absence of Start and Stop bits, many data words can be transmitted per second.	Extra Start and Stop bits slow down the transmission process relatively.
The synchronous device is more expensive to build as it must be smart enough to differentiate between the actual data and the special synchronous characters.	It is relatively cheaper.
Chances of data loss are relatively higher.	More reliable as the start and stop bits ensure that the sender and the receiver remain in step with one another.
It is more efficient.	It is relatively less efficient.
	

Question 3

Discuss Transmission Media in detail.

Answer

Transmission Media connects the message source with the message receiver by means of Guided or Unguided Media.

Guided Media/Bound Media: Guided Transmission Media uses a "cabling" system that guides the data signals along a specific path. Some of the common examples of guided media are Twisted Pair, Coaxial cable and Fiber optics.

- ◆ **Twisted-Pair Wire:** Twisted-pair is ordinary telephone wire, consisting of copper wire twisted into pairs. It is the most widely used media for telecommunications and is used for both voice and data transmissions. It is used extensively in home and office telephone systems and many LANs and WANs.
- ◆ **Coaxial Cable:** This telecommunication media consists of copper or aluminum wire wrapped with spacers to insulate and protect it. Coaxial cables can carry a large volume of data and allows high-speed data transmission used in high-service metropolitan areas for cable TV systems, and for short-distance connection of computers and peripheral devices. It is used extensively in office buildings and other work sites for local area networks.
- ◆ **Fiber Optics:** This media consists of one or more hair-thin filaments of glass fiber wrapped in a protective jacket. Signals are converted to light form and fired by laser in bursts. Optical fibers can carry digital as well as analog signals and provides increased speed and greater carrying capacity than coaxial cable and twisted-pair lines.

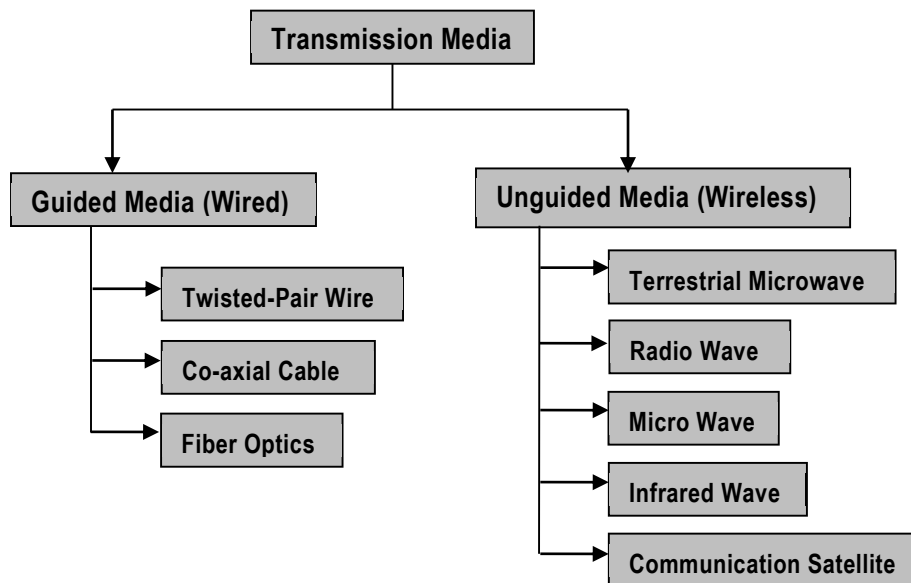

Unguided Media/Unbound Media: Unguided Transmission Media consists of a means for the data signals to travel but nothing to guide them along a specific path. The data signals are not

3.17 Information Technology

bound to a cabling media. Some of the common examples of unguided media are Terrestrial Microwave, Radio Waves, Micro Waves, Infrared Waves and Communication Satellites.

- ◆ **Terrestrial Microwave:** Terrestrial microwave media uses the atmosphere as the medium through which to transmit signals and is used extensively for high-volume as well as long-distance communication of both data and voice in the form of electromagnetic waves.
- ◆ **Radio Waves:** Radio waves are an invisible form of electromagnetic radiation that varies in wavelength from around a millimeter to 100,000 km, making it one of the widest ranges in the electromagnetic spectrum. Radio waves are most commonly used transmission media in the wireless Local Area Networks.
- ◆ **Micro Waves:** Microwaves are radio waves with wavelengths ranging from as long as one meter to as short as one millimeter, or equivalently, with frequencies between 300 MHz (0.3 GHz) and 300 GHz. These are used for communication, radar systems, radio astronomy, navigation and spectroscopy.
- ◆ **Infrared Waves:** Infrared light is used in industrial, scientific, and medical applications. Night-vision devices using infrared illumination allow people or animals to be observed without the observer being detected.
- ◆ **Communication Satellites:** Communication satellites use the atmosphere (microwave radio waves) as the medium through which to transmit signals. A satellite is some solar-powered electronic device that receives, amplifies, and retransmits signals; the satellite acts as a relay station between satellite transmissions stations on the ground (earth stations). They are used extensively for high-volume as well as long-distance communication of both data and voice.

Question 4

How can Client Computers be classified?

Answer

Client Computers can be classified as **Fat Client, Thin Client or Hybrid Client**.

- (i) **Fat / Thick Client:** A Fat Client or Thick Client is a client that performs the bulk of any data processing operations itself, and does not necessarily rely on the server. Thick clients do not rely on a central processing server because the processing is done locally on the user system, and the server is accessed primarily for storage purposes. For that reason, thick clients often are not well-suited for public environments. To maintain a thick client, IT needs to maintain all systems for software deployment and upgrades, rather than just maintaining the applications on the server. For example – Personal Computer.
- (ii) **Thin Client:** A Thin Client use the resources of the host computer. A thin client generally only presents processed data provided by an application server, which performs the bulk of any required data processing. A thin client machine is going to communicate with a central processing server, meaning there is little hardware and software installed on the user's machine. A device using web application (such as Office Web Apps) is a thin client.

- (iii) **Hybrid Client:** A Hybrid Client is a mixture of the above two client models. Similar to a fat client, it processes locally, but relies on the server for storing persistent data. This approach offers features from both the fat client (multimedia support, high performance) and the thin client (high manageability, flexibility). Hybrid clients are well suited for video gaming.

Question 5

Discuss some of the characteristics and issues of Client Server (C/S) architecture.

Answer

Some of the prominent characteristics of C/S architecture are as follows:

- ◆ **Service:** C/S provides a clean separation of function based on the idea of service. The server process is a provider of services and the client is a consumer of services.
- ◆ **Shared Resources:** A server can service many clients at the same time and regulate their access to the shared resources.
- ◆ **Transparency of Location:** C/S software usually masks the location of the server from the clients by redirecting the service calls when needed.
- ◆ **Mix-and-Match:** The ideal C/S software is independent of hardware or Operating System software platforms.
- ◆ **Scalability:** In a C/S environment, client workstations can either be added or removed and also the server load can be distributed across multiple servers.
- ◆ **Integrity:** The server code and server data is centrally managed, which results in cheaper maintenance and the guarding of shared data integrity. At the same time, the clients remain personal and independent.

Issues in Client/Server Network

- (i) When the server goes down or crashes, all the computers connected to it become unavailable to use.
- (ii) Simultaneous access to data and services by the user takes little more time for server to process the task.

Question 6

Discuss advantages and disadvantages of following:

- | | |
|---------------------------|-----------------------------|
| (a) Peer-to-Peer Network | (b) Single Tier Systems |
| (c) Two Tier Systems | (d) Three Tier Systems |
| (e) Centralized Computing | (f) Decentralized Computing |
| (g) Star Topology | (h) Ring Topology |
| (i) Bus Topology | (j) Mesh Topology |

Answer

(a) Peer-to-Peer Network

Advantages: Following are the major advantages of Peer-to-Peer networks:

- (i) Peer-to-Peer Networks are easy and simple to set up and only require a Hub or a Switch to connect all the computers together.
- (ii) It is very simple and cost effective.
- (iii) If one computer fails to work, all other computers connected to it continue to work.

Disadvantages: The major disadvantages of peer-to-peer networks are as below:

- (i) There can be a problem in accessing files if computers are not connected properly.
- (ii) It does not support connections with too many computers as the performance gets degraded in case of high network size.
- (iii) The data security is very poor in this architecture.

(b) Single Tier Systems

Advantages: A single-tier system requires only one stand-alone computer. It also requires only one installation of proprietary software which makes it the most cost-effective system available.

Disadvantages: It can be used by only one user at a time. A single tier system is impractical for an organization which requires two or more users to interact with the organizational data stores at the same time.

(c) Two Tier Systems

The advantages of Two-Tier systems are as follows:

- The system performance is higher because business logic and database are physically close.
- Since processing is shared between the client and server; more users could interact with system.
- By having simple structure, it is easy to setup and maintain entire system smoothly.

The disadvantages of Two-Tier systems are as follows:

- Performance deteriorates if number of users increases.
- There is restricted flexibility and choice of DBMS since data language used in server is proprietary to each vendor.

(d) Three Tier Systems

The following are the advantages of Three-Tier systems:

- **Clear separation of user-interface-control and data presentation from**

application-logic: Through this separation, more clients are able to have access to a wide variety of server applications. The two main advantages for client-applications are quicker development through the reuse of pre-built business-logic components and a shorter test phase.

- **Dynamic load balancing:** If bottlenecks in terms of performance occur, the server process can be moved to other servers at runtime.
- **Change management:** It is easy and faster to exchange a component on the server than to furnish numerous PCs with new program versions.

The disadvantages of Three-Tier systems are as below:

- It creates an increased need for network traffic management, server load balancing, and fault tolerance.
- Current tools are relatively immature and are more complex.
- Maintenance tools are currently inadequate for maintaining server libraries.

(e) Centralized Computing

Advantages are as follows:

- ◆ **Ease of management** – There are relatively few computers to manage;
- ◆ **Enhanced security** – The physical and logical securing of the computing environment can be more easily managed since there is only one location and a few computers;
- ◆ **Ease of control** – The introduction of change can be managed closely since there is only one location and a few computers;
- ◆ **Reduced cost of ownership** – Fewer computing elements to manage and therefore few people needed to manage them;
- ◆ **Multiple types of workload** – All of the work associated with the business runs at the central computing location.

Disadvantages are as follows:

- ◆ The central computer performs the computing functions and controls the remote terminals. In case of failure of central computer, the entire system will go down.
- ◆ Central computing relies heavily on the quality of administration and resources provided to its users. Empowerment of the central computer should be adequate by all means, else the usage suffers greatly.

(f) Decentralized Computing

Advantages are as follows:

3.21 Information Technology

- ◆ A decentralized system utilizes the potential of desktop systems to maximize the potential performance of the business applications.

Disadvantages are as follows:

- ◆ All computers have to be updated individually with new software, unlike a centralized computer system.

(g) Star Topology

Advantages are as follows:

- ◆ Several users can use the central unit at the same time.
- ◆ It is easy to add new nodes and remove existing nodes.
- ◆ A node failure does not bring down the entire network.
- ◆ It is easier to diagnose network problems through a central hub.

Disadvantages are as follows:

- ◆ The whole network is affected if the main unit “goes down,” and all communications stop. If it fails, there is no backup processing and communications capability and the local computers will be cut off from the corporate headquarters and from each other.
- ◆ Cost of cabling the central system and the points of the star network together are very high.

(h) Ring Topology

Advantages are as follows:

- ◆ Ring networks neither require a central computer to control activity nor does it need a file server.
- ◆ Each computer connected to the network can communicate directly with the other computers in the network by using the common communication channel, and each computer does its own independent applications processing.
- ◆ The ring network is not as susceptible to breakdowns as the star network, because when one computer in the ring fails, it does not necessarily affect the processing or communications capabilities of the other computers in the ring.
- ◆ Ring networks offer high performance for a small number of workstations or for larger networks where each station has a similar workload.
- ◆ Ring networks can span longer distances than other types of networks.
- ◆ Ring networks are easily extendable.

Disadvantages are as follows:

- ◆ Relatively expensive and difficult to install.
- ◆ Failure of one computer on the network can affect the whole network.

- ◆ It is difficult to troubleshoot a ring network.
- ◆ Adding or removing computers can disrupt the network.

(i) Bus Topology

Advantages are as follows:

- ◆ There is no host computer or file server which makes bus network reliable as well as easy to use and understand.
- ◆ If one of the microcomputers fails, it will not affect the entire network.
- ◆ Requires the least amount of cable to connect the computers together and therefore is less expensive than other cabling arrangements.
- ◆ Is easy to extend. Two cables can be easily joined with a connector, making a longer cable for more computers to join the network.
- ◆ A repeater can also be used to extend a bus configuration.

Disadvantages are as follows:

- ◆ Heavy network traffic can slow a bus considerably since any computer can transmit at any time.
- ◆ Each connection between two cables weakens the electrical signal.
- ◆ The bus configuration can be difficult to troubleshoot. A cable break or malfunctioning computer can be difficult to find and can cause the whole network to stop functioning.

(j) Mesh Topology

Advantages are as follows:

- ◆ Yields the greatest amount of redundancy in the event that if one of the nodes fails, the network traffic can be redirected to another node.
- ◆ Network problems are easier to diagnose.

Disadvantages are as follows:

- ◆ Installation and maintenance cost is very high as more cable is required in Mesh Topology.

Question 7

Discuss the common Switching techniques used in computer networking.

Answer

The common switching techniques used in computer networking are – **Circuit switching, Packet Switching and Message Switching.**

- ◆ **Circuit Switching:** When two nodes communicate with each other over a dedicated communication path, it is called Circuit Switching. An important property of circuit switching is the need to set up an end-to-end path before any data can be sent which can either be

permanent or temporary. Applications which use circuit switching may have to go through three phases: **Establish a circuit**, **Transfer of data** and **Disconnect the circuit**. The bandwidth is reserved all the way from sender to receiver and all the data packets follow the same path, thus, ensuring the sequence of data packets are in order.

- ◆ **Packet Switching:** The entire message is broken down into smaller transmission units called packets. The switching information is added in the header of each packet and transmitted independently. It is easier for intermediate networking devices to store smaller size packets and they do not take much resources either on carrier path or in the switches' internal memory. In packet switched network, first packet of a multi-packet message may be forwarded before the second one has fully arrived, thus reducing delay and improving throughput. Since, there is no fixed path, different packets can follow different path and thus they may reach to destination out of order.
- ◆ **Message Switching/ Store-and-Forward:** In message switching, no physical path is established between sender and receiver in advance. The whole message is treated as a data unit and is transferred in its entirety which contains the entire data being delivered from the source to destination node. A switch working on message switching first receives the whole message and buffers it until there are resources available to transfer it to the next hop. If the next hop is not having enough resource to accommodate large size message, the message is stored and switch waits. E-mail and voice mail are examples of message switching systems.

Question 8

Explain the OSI Model of communication in detail.

Answer

OSI Model – The International Standards Organization (ISO) developed a seven-layer Open Systems Interconnection (OSI) model to serve as a standard model for network architectures. Seven layers of OSI include the following:

- ◆ **Layer 7 or Application Layer:** This layer is closest to the end user and interacts with software applications and provides user services by file transfer, file sharing, etc. At this layer, communication partners are identified; quality of service is identified; user authentication and privacy are considered; any constraints on data syntax are identified; and database concurrency and deadlock situation controls are undertaken.
- ◆ **Layer 6 or Presentation Layer:** Also, referred as **Syntax Layer**, this layer is usually a part of an operating system that converts incoming and outgoing data from one presentation format to another (for example, from a text stream into a popup window with the newly arrived text). It further controls onscreen display of data, transforms data to a standard application interface, encryption and data compression.
- ◆ **Layer 5 or Session Layer:** This layer sets up, coordinates, and terminates conversations; exchanges and dialogs between the applications at each end. It deals with session and connection coordination and provides for full-duplex, half-duplex, or simplex operation, and

establishes check pointing, adjournment, termination, and restart procedures.

- ◆ **Layer 4 or Transport Layer:** This layer ensures reliable and transparent transfer of data between user processes; assembles and disassembles message packets and provides error recovery and flow control. Multiplexing and encryption are undertaken at this layer level.
- ◆ **Layer 3 or Network Layer:** The Network Layer provides the functional and procedural means of transferring variable length data sequences from a source to a destination via one or more networks, while maintaining the quality of service requested by the Transport Layer. The Network Layer makes a choice of the physical route of transmission; creates a virtual circuit for upper layers to make them independent of data transmission and switching; establishes, maintains, terminates connections between the nodes and ensure proper routing of data.
- ◆ **Layer 2 or Data Link Layer:** The Data Link Layer responds to service requests from the Network Layer and issues service requests to the Physical Layer. This layer transfers data between adjacent network nodes in a WAN or between nodes on the same LAN segment. This layer also specifies channel access control method and ensures reliable transfer of data through the transmission medium. It provides the functional and procedural means to transfer data between network entities and detects and possibly corrects errors that may occur in the Physical Layer.
- ◆ **Layer 1 or Physical Layer:** The Physical Layer is a hardware layer which specifies mechanical features as well as electromagnetic features of the connection between the devices and the transmission. Establishment and termination of a connection to a communications medium; participation in the process whereby the communication resources are effectively shared among multiple users; and modulation or conversion between the representation of digital data in user equipment and the corresponding signals transmitted over a communications channel are the major tasks of this layer.

Question 9

Discuss Encryption Model in computer network.

Answer

In Cryptography, encryption is the process of encoding messages (or information) in such a way that eavesdroppers or hackers cannot read it, but only authorized parties can. The Encryption Model defines the encryption of plaintext into ciphertext and decryption of ciphertext into plaintext.

- ◆ **Plaintext** is the message that is to be encrypted. It is transformed by a function that is parameterized by a key.
- ◆ **CipherText** is the output of the encryption process that is transmitted often by a messenger or radio.

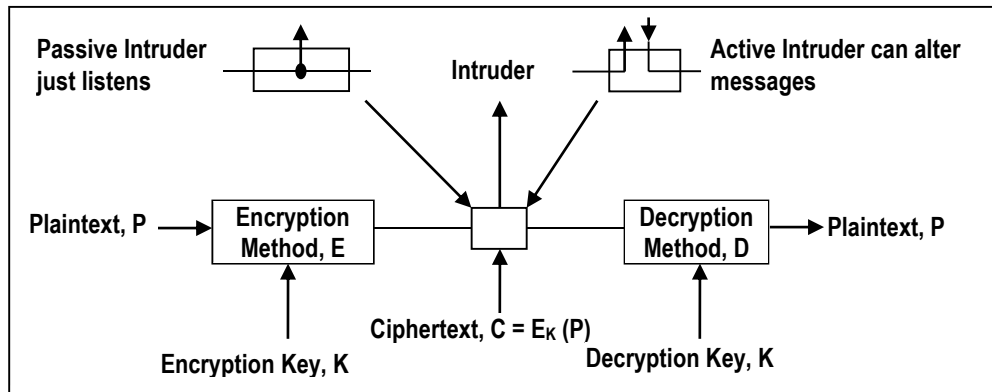

Encryption Model – The intruder may hear and accurately copies down the complete ciphertext. However, unlike the intended recipient, he does not know what the decryption key is and so cannot decrypt the ciphertext easily. Sometimes the intruder can not only listen to the communication channel (passive intruder) but can also record messages and play them back later, inject his own messages, or modify legitimate messages before they get to the receiver (active intruder). The art of breaking ciphers is known as **Cryptanalysis**, and the art of devising them (**Cryptography**) are collectively known as **Cryptology**.

Question 10

Discuss in brief, some of the popular Network Security Protocols.

Answer

Some of the popular network security protocols include **Secure Shell (SSH)**, **Secure File Transfer Protocol (SFTP)**, **HyperText Transfer Protocol Secure (HTTPS)** and **Secure Socket Layer (SSL)** etc.

- ◆ **SSH** – Secure Shell is a program to log into another computer over a network, to execute commands in a remote machine, and to move files from one machine to another. It provides strong authentication and secure communications over insecure channels. SSH protects a network from attacks such as IP spoofing, IP source routing, and DNS spoofing. An attacker cannot play back the traffic or hijack the connection when encryption is enabled. During ssh login; the entire login session including transmission of password is encrypted; therefore it is almost impossible for an outsider to collect passwords.
- ◆ **SFTP** – The SSH File Transfer Protocol (also known as Secure FTP and SFTP) is a computing network protocol for accessing and managing files on remote file systems. Unlike standard File Transfer Protocol (FTP), SFTP encrypts commands and data both, preventing passwords and sensitive information from being transmitted in the clear over a network.
- ◆ **HTTPS** – HyperText Transfer Protocol Secure (HTTPS) is a communication protocol for secure communication over a computer network with especially wide deployment on the

Internet. The security of HTTPS uses long term public and secret keys to exchange a short term session key to encrypt the data flow between client and server.

- ◆ **SSL** – It is a protocol that provides a secure channel between two machines operating over the Internet or an internal network. It is typically used when a web browser needs to securely connect to a web server over the inherently insecure Internet. In practice, SSL is used to secure online credit card transactions system logins and any sensitive information exchanged online; to secure the connection between an email client such as Microsoft Outlook and an email server such as Microsoft Exchange, to secure intranet based traffic such as internal networks, file sharing, extranets, and database connections etc.

Question 11

Discuss FCAPS model of network management.

Answer

FCAPS is the ISO Telecommunications Management Network model and framework for network management. It is an acronym for **Fault, Configuration, Accounting, Performance and Security**.

- (i) **Fault Management** – A fault is an event that has a negative significance. The goal of fault management is to recognize, isolate, correct and log faults that occur in the network. Most fault management systems poll the managed objects for error conditions and present this information to the network manager. Fault management identifies and isolates network issues; proposes problem resolution; and subsequently logs the issues and associated resolutions.
- (ii) **Configuration Management** – Monitors network and system configuration information so that the impact on network operations (hardware and software elements) can be tracked and managed. Network changes, additions, and deletions need to be coordinated with the network management personnel.
- (iii) **Accounting Management** – Accounting management is concerned with tracking network utilization information, such that individual users, departments, or business units can be appropriately billed or charged for accounting purposes. For non-billed networks, accounting refers to administration whose primary goal is to administer the set of authorized users by establishing users, passwords, and permissions and to administer the operations of the equipment such as by performing software backup and synchronization.
- (iv) **Performance Management** – Measures and makes network performance data available so that performance can be maintained and acceptable thresholds. It enables the manager to prepare the network for the future, as well as to determine the efficiency of the current network. The network performance addresses the throughput, network response times, packet loss rates, link utilization, percentage utilization, error rates and so forth.
- (v) **Security Management** – Controls access to network resources as established by organizational security guidelines. Most network management systems address security regarding network hardware such as someone logging into a router. Security management

3.27 Information Technology

functions include managing network authentication, authorization, and auditing, such that both internal and external users only have access to appropriate network resources, configuration and management of network firewalls, intrusion detection systems, and security policies (such as access lists).

Question 12

Discuss strategic capabilities of Internet along with their business applications.

Answer

The strategic capabilities of Internet include the following:

- (i) **Overcome geographic barriers:** Capture information about business transactions from remote locations. This provides better customer service by reducing delay in filling orders and improves cash flow by speeding up the billing of customers. For example - Use the Internet and Extranet to transmit customer orders from travelling salespeople to a corporate data centre for order processing and inventory control.
- (ii) **Overcome time barriers:** Provide information to remote locations immediately after it is requested. Credit inquiries can be made and answered in seconds. For example - Credit authorization at the point of sale using online POS networks.
- (iii) **Overcome cost barriers:** Reduce the cost of more traditional means of communication. This reduces expensive business trips; allows customers, suppliers, and employees to collaborate, thus improving the quality of decisions reached. For example - Desktop videoconferencing between a company and its business partners using the Internet, Intranet and Extranet.
- (iv) **Overcome structural barriers:** Support linkages for competitive advantage. Fast, convenient services lock in customers and suppliers. For example - Business-to-business electronic commerce websites for transactions with suppliers and customers using the Internet and Extranet.

Question 13

What do you understand by the term 'e-Commerce'? Discuss its benefits and risks involved.

Answer

e-Commerce is the process of doing business electronically. It refers to the use of technology to enhance the processing of commercial transactions between a company, its customers and its business partners. It involves the automation of a variety of business-to-business and business-to-consumer transactions through reliable and secure connections.

Benefits of e-Commerce Application and Implementation are as follows:

- ◆ Reduction in costs to buyers from increased competition in procurement as more suppliers are able to compete in an electronically open marketplace.

- ◆ Reduction in errors, time and overhead costs in information processing by eliminating requirements for re-entering data.
- ◆ Reduction in costs to suppliers by electronically accessing on-line databases of bid opportunities, on-line abilities to submit bids, and on-line review of rewards.
- ◆ Reduction in time to complete business transactions, particularly from delivery to payment.
- ◆ Creation of new markets through the ability to easily and cheaply reach potential customers.
- ◆ Easier entry into new markets especially geographically remote markets for enterprises regardless of size and location.
- ◆ Better quality of goods as specifications are standardized and competition is increased and improved variety of goods through expanded markets and the ability to produce customized goods.
- ◆ Faster time to market as business processes are linked, thus enabling seamless processing and eliminating time delays.
- ◆ Optimization of resource selection as businesses form cooperative teams to increase the chances of economic successes, and to provide the customer products and capabilities more exactly meeting the requirements.
- ◆ Reduction in inventories and risk of obsolete inventories as the demand for goods and services is electronically linked through just-in-time inventory and integrated manufacturing techniques.
- ◆ Reduction in overhead costs through uniformity, automation, and large-scale integration of management processes.
- ◆ Reduction in use of ecologically damaging materials through electronic coordination of activities and the movement of information rather than physical objects).
- ◆ Reduction in advertising costs.

Risks involved in e-Commerce are as follows:

- ◆ **Problem of anonymity:** There is need to identify and authenticate users in the virtual global market where anyone can sell to or buy from anyone, anything from anywhere.
- ◆ **Repudiation of contract:** There is possibility that the electronic transaction in the form of contract, sale order or purchase by the trading partner or customer may be denied.
- ◆ **Lack of authenticity of transactions:** The electronic documents that are produced in the course of an e-Commerce transaction may not be authentic and reliable.
- ◆ **Data Loss, Theft or Duplication:** The data transmitted over the Internet may be lost, duplicated, tampered with or replayed.
- ◆ **Attack from hackers:** Web servers used for e-Commerce may be vulnerable to hackers.

3.29 Information Technology

- ◆ **Denial of Service:** Service to customers may be denied due to non-availability of system as it may be affected by viruses, e-mail bombs and floods.
- ◆ **Non-recognition of electronic transactions:** e-Commerce transactions as electronic records and digital signatures may not be recognized as evidence in courts of law.
- ◆ **Lack of audit trails:** Audit trails in e-Commerce system may be lacking and the logs may be incomplete, too voluminous or easily tampered with.
- ◆ **Problem of piracy:** Intellectual property may not be adequately protected when such property is transacted through e-Commerce.

Question 14

What are the different types of e-Commerce?

Answer

The general classes of e-Commerce applications are as follows:

- (i) **Business-to-Business (B2B) e-Commerce:** B2B refers to the exchange of services, information and/or products from one business to another. B2B electronic commerce typically takes the form of automated processes between trading partners and is performed in much higher volumes than Business-to-Consumer (B2C) applications. B2B can also encompass marketing activities between businesses and not just the final transactions that result from marketing.
- (ii) **Business-to-Consumer (B2C) e-Commerce:** It is defined as the exchange of services, information and/or products from a business to a consumer, as opposed to between one business and another. This model saves time and money by doing business electronically but customers must be provided with safe and secure as well as easy-to-use and convenient options when it comes to paying for merchandise. This minimizes internal costs created by inefficient and ineffective supply chains and creates reduces end prices for the customers.
- (iii) **Consumer-to-Business (C2B) e-Commerce:** In C2B e-Commerce model, consumers directly contact with business vendors by posting their project work online so that the needy companies review it and contact the consumer directly with bid. The consumer reviews all the bids and selects the company for further processing. Some examples are guru.com, rentacoder.com, getacoder.com, freelancer.com.
- (iv) **Consumer-to-Consumer (C2C) e-Commerce:** C2C e-Commerce is an Internet-facilitated form of commerce that provides a virtual environment in which consumers can sell to one another through a third-party intermediary.
- (v) **Business-to-Government (B2G) e-Commerce:** B2G e-Commerce, also known as e-Government, refers to the use of information and communication technologies to build and strengthen relationships between government and employees, citizens, businesses, non-profit organizations, and other government agencies.

- (vi) **Business-to-Employee (B2E) e-Commerce:** B2E e-Commerce, from an intra-organizational perspective provides the means for a business to offer online products and services to its employees.

Question 15

Differentiate between Host Based & Network Intrusion Detection System.

Answer

Differences between Host Based Intrusion Detection System and Network Based Intrusion Detection System are as follows:

	Host Based Intrusion Detection System	Network Based Intrusion Detection System
Deterrence	Strong deterrence for insiders	Strong deterrence for outsiders
Detection	Strong insider detection, weak outsider detection	Strong outsider detection, weak insider detection
Attack Anticipation	Good at trending and detecting suspicious behavior patterns	None
Damage Assessment	Excellent for determining extent of compromise	Very weak damage assessment capabilities
Response	Weak real-time response, good for long term attacks	Strong response against outsider attacks
Scope	Narrow in scope, monitors specific activities	Broad in scope
Dependency	Host dependent	Host independent.

Question 16

Write short note on the following:

- (a) Internet
- (b) Intranet
- (c) Extranet
- (d) HTTPS
- (e) Firewall

Answer

- (a) **Internet:** The Internet is the massive global system that connects computer networks around the world together. Millions of private, public, academic, business and government networks worldwide connect with each other over the internet to share massive amounts

3.31 Information Technology

of information, resources and services. The Internet uses the standard Internet protocol suite (TCP/IP) to allow us to connect to each other. It has numerous information resources and services, such as the web pages of the World Wide Web (WWW), games, videos, images, e-mail, social networking, etc.

The Internet carries information from all streams; traditional, such as newspaper, book and other print publishing; and modern such as blogging and web feeds. It also enables new forms of human interactions through, instant messaging, e-mail, Internet forums, and social networking.

- (b) **Intranet:** Intranet is an internal network used by companies to connect their computers on a network. Intranet is accessible only by the organization's members, employees, or others with authorization. A firewall surrounds an Intranet that fends off unauthorized access. The Intranet is based on TCP/IP protocol and is inaccessible from the outside. An Intranet resides behind a firewall and is accessible only to people who are members of the same company or organization.

Intranet is mainly used by corporations as it is a secure network and is much less expensive to build and manage than private networks based on proprietary protocols. Only the members of the corporation with authorized access may log on and access the network and the data on the network. Like all networks, the Intranet is mainly used to share data, information, resources, company programs, software applications, as well as facilitate communication between people or work groups within the company. Intranet improves the data sharing capability and overall knowledge base of the company's employees.

- (c) **Extranet:** Extranet is basically an internal network that can be accessed externally. The extranet can be thought as an extension of the company's intranet. People from outside the company can have a limited access to the company's internal network for business or education related purposes. The access may be granted to the organization's partners, vendors, suppliers, current and potential customers, etc. Extranet refers to an Intranet that is partially accessible to authorized outsiders. An Extranet provides various levels of accessibility to outsiders having a valid username and password.

The Extranet requires security and privacy, so that the information on the network is not wrongly accessed or misused by external parties. In order to protect the network, the extranets can incorporate firewall server management, the issuance and use of digital certificates or similar means of user authentication, encryption of messages, and the use of virtual private networks (VPNs) that tunnel through the public network.

- (d) **HTTPS:** HyperText Transfer Protocol Secure (HTTPS) is a communications protocol for secure communication over a computer network, with especially wide deployment on the Internet. The security of HTTPS uses long term public and secret keys to exchange a short term session key to encrypt the data flow between client and server.
- (e) **Firewall:** Firewall is a device that forms a barrier between a secure and an open environment when the latter environment is usually considered hostile, for example, the

Internet. It acts as a system or combination of systems that enforces a boundary between more than one networks. Access controls are common form of controls encountered in the boundary subsystem by restricting the use of system resources to authorized users, limiting the actions authorized users can take with these resources and ensuring that the users obtain only authentic system resources.

Question 17

Define Virtual Private Networks (VPN).

Answer

Virtual Private Network: It is a private network that uses a public network (usually the Internet) to connect remote sites or users together. By using a VPN, businesses ensure security – anyone intercepting the encrypted data can't read it. VPN is a secure network that uses the Internet as its main backbone network, but relies on the firewalls and other security features of the Internet and Intranet connections and those of participating organizations.

Question 18

What do you mean by threat and vulnerability? Explain any three facts responsible for occurrence of vulnerabilities in the software.

Answer

Threat: A threat is anything that can disrupt the operation, functioning, integrity, or availability of a network or system.

Vulnerability: Vulnerability is an inherent weakness in the design, configuration, or implementation of a network or system that renders it susceptible to a threat.

The following facts are responsible for occurrence of vulnerabilities in the software:

- **Software Bugs** - Software bugs are so common that users have developed techniques to work around the consequences, and bugs that make saving work necessary every half an hour or crash the computer every so often are considered to be a normal part of computing. For example - buffer overflow, failure to handle exceptional conditions, access validation error, input validation errors are some of the common software flaws.
- **Timing Windows** - This problem may occur when a temporary file is exploited by an intruder to gain access to the file, overwrite important data, and use the file as a gateway for advancing further into the system.
- **Insecure default configurations** - Insecure default configurations occur when vendors use known default passwords to make it as easy as possible for consumers to set up new systems. Unfortunately, most intruders know these passwords and can access systems effortlessly.
- **Trusting Untrustworthy information** - This is usually a problem that affects routers, or those computers that connect one network to another. When routers are not programmed

3.33 Information Technology

to verify that they are receiving information from a unique host, bogus routers can gain access to systems and do damage.

- **End users** - Generally, users of computer systems are not professionals and are not always security conscious. For example, when the number of passwords of a user increases, user may start writing them down, in the worst case to places from where they are easy to find. In addition to this, users do human errors, for example save confidential files to places where they are not properly protected.

Question 19

How Extranets are used by Business Organization?

Answer

The Extranets can be used by business organizations in some of the following ways:

- Share product catalogs exclusively with wholesalers or those “in the trades”.
- Collaborate with other companies on joint development efforts.
- Jointly develop and use training programs with other companies.
- Provide or access services provided by one company to a group of other companies; and
- Share news of common interest exclusively with partner companies.
- Establish direct private network links between themselves, or create private secure internet links between them called virtual private networks.
- Use the unsecured internet as the extranet link between its intranet and consumers and others, but rely on encryption of sensitive data and its own firewall systems to adequate security.

Question 20

Briefly explain three tiers in Three tier architecture.

Answer

The three tiers in Three-tier architecture are as follows:

- **Presentation Tier:** This tier occupies the top level, communicates with other tiers and displays information related to services available on a website.
- **Application Tier:** Also called the Middle tier, Logic tier, Business Logic or Logic tier; this tier controls application functionality by performing detailed processing.
- **Database Tier:** This tier houses the database servers where information is stored and retrieved. Data in this tier is kept independent of application servers or business logic.

Question 21

Which network topology can be used in case of Military Installations with a very small number of nodes and why it should be used? List advantages and disadvantages of such network topology.

Answer

In case of Military installations with a very small number of nodes, **Mesh Network topology** should be used.

In fully interconnected Mesh topology, each node is connected by a dedicated point to point link to every node and thus the reliability is very high which is of prime importance in any military installations. Even if one node fails, Mesh topology provides high degree of redundancy with each node connected to remaining nodes.

Advantages of mesh network are as follows:

- ◆ Mesh network topology yields the greatest amount of redundancy in the event that if one of the nodes fails, the network traffic can be redirected to another node.
- ◆ Network problems are easier to diagnose.

Disadvantage of mesh network are as follows:

- ◆ Mesh networks are not very common because of its high cost of installation and maintenance.
- ◆ More cabling is required than any other configuration.

Question 22

Mention the two categories of encryption/decryption methods. What are two basic approaches to encryption?

Answer

(a) The two categories of encryption/decryption methods are: the Secret Key Method and the Public Key Method.

- ◆ **Secret Key Method:** In Secret key encryption/decryption method, the same key is used by both sender and the receiver. The sender uses this key and an encryption algorithm to encrypt data; the receiver uses the same key and the corresponding decryption algorithm to decrypt the data.
- ◆ **Public Key Method:** In Public key encryption, there are two keys: a private key which is kept by the receiver and the public key which is announced to the public.

The two basic approaches to Encryption are as follows:

- ◆ **Hardware Encryption:** Hardware encryption devices are available at a reasonable cost, and can support high- speed traffic. If the Internet is being used to exchange information among branch offices or development collaborators, for instance, use of such devices can ensure that all traffic between these offices is secure.

3.35 Information Technology

- ◆ **Software encryption:** Software encryption is typically employed in conjunction with specific applications. Certain electronic mail packages, for example, provide encryption and decryption for message security.

Question 23

What are the key aspects to be considered in implementing e-commerce?

Answer

The key aspects to be considered in implementing e-commerce are as follows:

- ◆ Involvement of stakeholders, key trading partners, and external auditors to obtain insight into the design and deployment of e-commerce solution;
- ◆ Implementing appropriate policies, standards and guidelines;
- ◆ Performing cost benefit analysis and risk assessment to ensure value delivery;
- ◆ Implementing the right level of security across all layers and processes;
- ◆ Establishing and implementing the right level of baseline (best practice) controls;
- ◆ Integration of e-Commerce with the business process and the physical delivery channels;
- ◆ Providing adequate user training; and
- ◆ Performing post implementation review to ensure controls are working as envisaged.

Question 24

What are the characteristics of Star Network?

Answer

The characteristics of Star network are as follows:

- ◆ *The star network, a popular network configuration, involves a central unit that has several terminals tied into it. In other words, it ties end user computers to a central computer.*
- ◆ *The central unit in the star network acts as the traffic controller among all the other computers tied to it. The central computer is usually a mainframe (host), which acts as the file server.*
- ◆ *A star network is well suited to companies with one large data processing facility shared by several smaller departments. Many star networks take the form of hierarchical networks with a centralized approach.*

Question 25

What is the basic objective for providing network security? Explain the major functions and services performed by the Physical Layer (Layer 1) of OSI Model of Network Architecture.

Answer

The basic objective for providing network security is two-fold –

- ◆ *To safeguard assets, and*
- ◆ *To ensure and maintain the data integrity. The boundary subsystem is an interface between the potential users of a system and the system itself. Controls in the boundary subsystem have the following purposes:*
- ◆ *To establish the system, resources that the users desire to employ; and*
- ◆ *To restrict the actions undertaken by the users who obtain the system resources to an authorized set.*

The major functions and services performed by the Physical Layer (Layer 1) of OSI Model of Network Architecture are as follows:

- ◆ *Establishment and termination of a connection to a communications medium.*
- ◆ *Participation in the process whereby the communication resources are effectively shared among multiple users. For example – contention, resolution and flow control.*
- ◆ *Modulation or conversion between the representation of digital data in user equipment and the corresponding signals transmitted over a communications channel. These are signals operating over the physical cabling (such as copper and optical fiber) or over a radio link.*

Question 26

What do you understand by n-tier architecture?

Answer

***n-tier Architecture:** In a client-server architecture in which presentation, application processing, and data management functions are logically separated. By segregating an application into tiers, developers acquire the option of modifying or adding a specific layer, instead of reworking on entire application. For example, an application that uses middleware to service data requests between a user and a database employs multi-tier architecture. The most widespread use of multi-tier architecture is the three-tier architecture.*

Question 27

What does FCAPS stand for? Explain it regarding Network Management function.

Answer

A common way of characterizing network management functions is FCAPS - Fault, Configuration, Accounting, Performance and Security. FCAPS is the ISO Telecommunications Management Network model and framework for network management.

- (i) **Fault Management** - A fault is an event that has a negative significance. The goal of fault management is to recognize, isolate, correct and log faults that occur in the network. Most fault management systems poll the managed objects for error conditions and present this information to the network manager. Fault management identifies and isolates network issues, proposes problem resolution, and subsequently logs the issues and associated resolutions.
- (ii) **Configuration Management** - Monitors network and system configuration information so that the impact on network operations (hardware and software elements) can be tracked and managed. Network changes, additions, and deletions need to be coordinated with the network management personnel.
- (iii) **Accounting Management** - Accounting management is concerned with tracking network utilization information, such that individual users, departments, or business units can be appropriately billed or charged for accounting purposes. For non-billed networks, accounting refers to administration whose primary goal is to administer the set of authorized users by establishing users, passwords, and permissions and to administer the operations of the equipment such as by performing software backup and synchronization.
- (iv) **Performance Management** - Measures and makes network performance data available so that performance can be maintained and acceptable thresholds. It enables the manager to prepare the network for the future, as well as to determine the efficiency of the current network. The network performance addresses the throughput, network response times, packet loss rates, link utilization, percentage utilization, error rates and so forth.
- (v) **Security Management** - Controls access to network resources as established by organizational security guidelines. Most network management systems address security regarding network hardware, such as someone logging into a router. Security management functions include managing network authentication, authorization, and auditing, such that both internal and external users only have access to appropriate network resources, configuration and management of network firewalls, intrusion detection systems, and security policies (such as access lists).

Question 28

List out some features of computerized networking in an organization.

Answer

With growth of business, organizations need good communication between employees to maintain consistency and efficiency. It is being achieved by sharing information such as common files, databases and business application software via telecommunication network and computers. Followings features are commonly seen due to computerized networking in an organization:

- (i) **File Sharing:** It provides for sharing and grouping of data files via network.
- (ii) **User Interface:** In computerized networking, network computers and other thin clients provide a browser based user interface for processing small application programs called applets.
- (iii) **Hardware Resource Sharing:** It provides sharing of computer hardware resources such as hard disk, printers etc. by multiple users simultaneously that save cost of installing and maintaining multiple resources.
- (iv) **System and Application Software:** Networks can provide for/include Application Servers for multiuser operating systems, web server software and application software applets.
- (v) **Remote Access:** Network allows users to remotely access the data and information. from organizations' network via internet in cost effective manner.
- (vi) **Shared databases:** Network facilitates simultaneous access to shared databases to multiple users at the same time by ensuring the integrity of database.
- (vii) **Fault Tolerance:** Computerized networking allows for primary and secondary line of data and programs backups to help defense against accidental data losses against faults or failures. Additional measures can also be taken by adding un-interruptible power supply to handle power failures.
- (viii) **Internet Access and Security:** It provides access to the internet for transfer of document and access world wide web by maintaining security thru firewall in the organization's network.

Exercise

1. Discuss the benefits of a computer network in an organization.
2. What is Network Management in Computer Networks and what functions does it perform?
3. Discuss some of the characteristics of Local Area Network (LAN).
4. Discuss the working of Client/Server architecture.
5. Discuss Multi-Tier architecture.
6. What are various threats to a computer network's security?
7. What is Vulnerability? What are the facts that are responsible for occurrence of vulnerabilities in software?
8. What are the steps followed by a security program?
9. What are the various ways available for a user to connect to an Internet Service Provider?
10. Discuss Internet architecture.

3.39 Information Technology

11. *What are the possible ways in which Internet can be used in an effective manner?*
12. *Discuss the business uses of the Internet, Intranet and Extranet.*
13. *What do you understand by the term "Mobile Commerce"?*
14. *What is Electronic Fund Transfer? Discuss some examples of EFT Systems.*
15. *Differentiate between Centralized Computing and Decentralized Computing.*
16. *Discuss various Network Security Techniques in brief.*

4

Business Information Systems

4.1 Introduction

Information technologies, including Internet-based information systems, are playing vital and expanding roles in business. Information technology can help all kinds of businesses improve the efficiency and effectiveness of their business processes, managerial decision making and workgroup collaboration, which strengthens their competitive positions in rapidly changing market places. **Business Information Systems (BIS)** is a preferred software engine for the development of Information Technology (IT) in most recent years. This chapter summarizes in about various Information Systems, their application and their impact on organizations.

4.2 Information Technology as a Key Business Enabler & Driver

Information represents an organization's tangible and intangible resources and all transactions relating to those resources. Information influences the way an organization operates. The right information, if it is transported to the right person, in the right fashion, and at the right time, can progress and guarantee organizational effectiveness and competence. The BIS is the mechanism used to manage and control the information resource.

4.3 Information Systems

Information System: An **Information System (IS)** is a combination of people, hardware, software, communication devices, network and data resources that processes (can be storing, retrieving, transforming information) data and information for a specific purpose. Any specific Information System aims to support operations, management and decision-making.

4.3.1 Components of Information System

The main aim and purpose of each Information System is to convert the data into information which is useful and meaningful. People, Hardware, Software, and Data Resources are four basic resources of Information Systems; a process is required to convert data into information for end users. Any Information process consists of input, processing, output, storage, and control processes.

Business Information System: **Business Information Systems (BIS)** may be defined as systems integrating Information Technology, people and business.

4.4 Organizations, Information Systems and Business Processes

Business Process: A **Business Process** is an activity or set of activities that will accomplish a specific organization goal. A business process has a goal, specific inputs and outputs, uses resources, and has a number of activities that are performed in some order, creates value of some kind for the customer and may affect more than one organizational unit.

4.5 Information Systems and their role in Businesses

Many business organizations obtain a competitive advantage by employing new information systems. The backbone of Information System is the World Wide Web, Internet; or within a business a Local Area Network (LAN), along with EDI, EIS, ERP, SCM, e-CRM, e-Commerce and host of others, which portray new ways in which IS can be employed to cultivate business.

4.6 Types of Information Systems

Types of Information Systems	Description	Example	Groups Served
Strategic - Level Systems	Used for strategic managers to track and deal with strategic issues, assisting long-range planning.	ESS	For Senior Managers
Management -Level Systems	Used for the monitoring, controlling, decision-making, and administrative activities of middle management.	MIS and DSS	Middle Managers
Knowledge - Level Systems	These systems support discovery, processing and storage of knowledge and data workers. These further control the flow of paper work and enable group working.	KWS and OAS	Knowledge and Data Workers
Operational - Level Systems	Support operational managers tracking elementary activities that include tracking customer orders, invoice tracking, etc. Operational-level systems ensure that business procedures are followed.	TPS	Operational Managers

4.6.1 Transaction Processing System (TPS)

A **Transaction Processing System (TPS)** may be defined as a type of information system that collects, stores, modifies and retrieves the day-to-day data transactions of an enterprise. The pre-requisites of **ACID Test** for any TPS are **Atomicity, Consistency, Isolation and Durability**.

<p>4.6.2 Office Automation System (OAS)</p> <p>Office Automation System (OAS) is amalgamation of hardware, software, and other resources used to smooth the progress of communications and augment efficiency. Office automation refers to the use of computer and software to digitally generate, collect, store, manipulate, and relay office information needed for accomplishing basic tasks and goals.</p>
<p>4.6.3 Knowledge Management System (KMS)</p> <p>Knowledge Management System (KMS) refer to any kind of IT system that stores and retrieves knowledge, improves collaboration, locates knowledge sources, mines repositories for hidden knowledge, captures and uses knowledge, or in some other way enhances the KM process. Explicit and Tacit are two broad types of knowledge. A Knowledge discovery in database system is a value – added Intranet with facilities to search and identify captured knowledge or identify experts who have the knowledge.</p> <p>Knowledge Discovery and Data Mining (KDD) fundamentally deals with ways and means of capturing and making obtainable knowledge of the experts to others, in electronic form. KDD systems also assist us establish, contact and communicate with experts (knowledgeable people) on various subjects, surrounded by our organization, or perhaps even outside.</p>
<p>4.6.4 Management Information System (MIS)</p> <p>Most simply, Management Information System is an integrated, user-machine system for providing information to support operation, management and decision-making functions in an organization. In other words, Management Information System is a system which provides accurate, timely and meaningful data for management planning, analysis and control to optimize the growth of the organization. For example - Airline reservations (seat, booking, payment, schedules, boarding list, special needs, etc.), Bank operations (deposit, transfer, withdrawal) electronically with a distinguish payment gateways, etc.</p>
<p>4.6.5 Decision Support System (DSS)</p> <p>A Decision Support System (DSS) is a computer-based information system that supports business or organizational decision-making activities. DSSs serve the management, operations, and planning levels of an organization (usually mid and higher management) and help to make decisions, which may be rapidly changing and not easily specified in advance. DSS can be either fully computerized, human or a combination of both. DSS has four basic components: The user, one or more databases, Planning languages and Model Base.</p>
<p>4.6.6 Executive Information Systems (EIS)</p> <p>An Executive Information System (EIS) is the nature of IS used by executives to access and administer the data they entail to make informed business decisions. Even though there are tools for managing an Executive Information System, the EIS in itself is not an instrument, but rather, an infrastructure within a company. Components of an EIS are Hardware, Software, User Interface and Telecommunication.</p>

4.7 Specialized Systems

Specialized Systems provide comprehensive end to end IT solutions and services (including systems integration, implementation, engineering services, software application customization and maintenance) to various sectors to confront challenges, and convert every challenge into an opportunity. For example- ERP, SCM, CRM, HRMS etc.

4.7.1 Enterprise Resource Planning (ERP)

Enterprise Resource Planning (ERP) systems integrate internal and external management information across an entire organization—taking on finance/accounting, manufacturing, sales and service, customer relationship management etc., and control the connections to exterior stakeholders.

Diverse stages involved in ERP implementation are - Inventory Control, ABC Analysis, Economic Order Quantity (EoQ), Just-In-Time (JIT), Material Requirement Planning (MRP-I), Manufacturing Resource Planning – II (MRP-II), Distribution Resource Planning (DRP), Enterprise Resource Planning (ERP), Money Resource Planning (MRP-III) and EIS-Web Enabled. Some of the "popular" ERP packages are SAP, JD Edwards, Baan, Oracle 9 i.

4.7.2 Customer Relationship Management (CRM)

Customer Relationship Management (CRM) may be defined as a business process in which client relationships; customer loyalty and brand value are built through marketing strategies and activities. CRM allows businesses to develop long-term relationships with established and new customers while helping modernize corporate performance. CRM incorporates commercial and client-specific strategies via employee training, marketing planning, relationship building and advertising.

CRM establishes the benefits of generating customer loyalty, raising a market intelligence enterprise and an integrated relationship. CRM applications smoothen the progress to capture, consolidate, analysis and enterprise-wide dissemination of data from existing and potential customers.

4.7.3 Supply Chain Management (SCM)

Supply Chain Management (SCM) is a chain that starts with customers and ends with customers. It may be defined as the process of planning, implementing and controlling the operations of the supply chain with the purpose of satisfying the customer's requirement as efficiently as possible. Supply Chain spans all movement and storage of raw materials, Work-in-process, inventory and finished goods from the point of origin to the point of consumption. Components of SCM are **Procurement/Purchasing, Operations, Distribution and Integration.**

4.7.4 Human Resource Management Systems (HRMS)

A **Human Resources Management System (HRMS)** is a software application that coalesce many human resources functions, together with benefits of administration, payroll, recruiting and training, and performance analysis and assessment into one parcel. In other words, HRMS or Human Resources Information System (HRIS) refers to the systems and processes at the intersection between Human Resource Management (HRM) and Information Technology.

Some of the key modules of HRMS are **Workforce Management, Time and Attendance Management, Payroll Management, Training Management, Compensation Management, Recruitment Management, Personnel Management, Organizational Management, Employee Self Service (ESS) and Analytics.**

4.7.5 Core Banking System (CBS)

Nowadays, most banks use core banking applications to sustain their operations where **CORE** stands for "**Centralized Online Real-time Environment**". **Core Banking System (CBS)** may be defined as the set of basic software components that manage the services provided by a bank to its customers through its branches (branch network). In other words, the platform where communication technology and information technology are merged to suit core needs of banking is known as **Core Banking Solutions (CBS)**. Normal core banking functions will include deposit accounts, loans, mortgages and payments. Banks make these services available across multiple channels like ATMs, Internet banking, and branches.

4.7.6 Accounting Information System (AIS)

Accounting Information System (AIS) is defined as a system of collection, storage and processing of financial and accounting data that is used by decision makers. AIS is generally a computer-based method for tracking accounting activity in conjunction with information technology resources. The resulting statistical reports can be used internally by management or externally by other interested parties including investors, creditors and tax authorities. Six key elements that compose the typical Accounting Information System are **People, Procedures and Instructions, Data, Software, Information Technology Infrastructure and Internal controls.**

4.8 Artificial Intelligence

Artificial Intelligence (AI) is a research field that studies how to comprehend the intelligent human behaviors on a computer. The decisive objective of AI is to make a computer that can discover, sketch, and crack problems in parallel. Expert systems, Pattern Recognition, Natural language processing, and many others are some of the various purposes on which AI may be applied.

4.9 Expert System

An **Expert System (ES)** is a computerized information system that allows non-experts to make decisions comparable to those of an expert. The aim of the Expert System is to have a team of seasoned specialists holding industry-wide experience who further spread across implementations. Expert system takes into consideration Knowledge base, Database of facts, Inference Engine, Explanation mechanism and User Interface. Expert Systems can be **Example-based, Rule-based or Frame-based.**

<h3>4.10 Business Intelligence</h3>
<p>Business Intelligence (BI), in simple words, refers to the process of collecting and refining information from many sources, analyzing and presenting the information in useful ways so that users can make better business decisions. BI enables managers to see things with more clarity, and empowers them to peek into the possible future.</p>
<h4>4.10.1 Business Intelligence Tools</h4>
<p>Business Intelligence Tools are a type of software that is designed to retrieve, analyze and report data. Some of the key Business Intelligence tools are Simple Reporting and Querying, Business Analysis, Dashboards, Scorecards, and Data Mining or Statistical Analysis.</p>
<h4>4.10.2 Business Reporting through MIS and IT</h4>
<p>Business Intelligence (BI) caters to strategic, tactical and operational needs and provides a platform for complete, comprehensive performance management for today's global, competitive businesses. Business reports are routinely assigned to facilitate us to accomplish conclusions about a trouble or issue; demonstrate short and apparent communication skills; endow with recommendations for upcoming accomplishing; exhibit our analytical, reasoning, and evaluation skills in identifying and weighing-up potential solutions and outcomes; pertain business and management theory to a practical situation and scrutinize obtainable and potential solutions to a problem, situation, or question.</p> <ul style="list-style-type: none"> ◆ Some of the benefits for micro-businesses and small to medium enterprises are paperless lodgment; electronic record keeping; pre-filled forms; ease of sharing; secure AUSkey authentication and same-time validation. ◆ Some of the benefits for large business are use of a single reporting language to report to government - eXtensible Business Reporting Language (XBRL); reduce costs; streamline of the process of aggregating data; increased access to comparable performance information; secure AUSkey authentication and same-time validation.
<h3>4.11 Importance of Access and Privilege Controls</h3>
<p>To safeguard software systems, procedures are developed and implemented for protecting them from unauthorized modification, disclosure or destruction to ensure that information remains accurate, confidential and is available when required. Access controls help us to restrict whom and what accesses our information resources, and they possess four general functions: Identity verification, Authentication, Authorization, and Accountability. These functions work together to grant access to resources and constrain what a subject can do with them.</p>
<h4>4.11.1 Approaches to Access Control</h4>
<p>Role-based Access Control (RBAC) and Rules-based Access Control (RAC) are the two major approaches to establish access controls while safeguarding the software system.</p>

<p>4.11.2 Principle of Least Privilege</p> <p>This is a fundamental principle of information security which refers to give only those privileges to a user account that are essential to that user's work. When applied to users, the terms Least User Access or Least-privileged User Account (LUA) are also used, referring to the concept that all user accounts at all times should run with as few privileges as possible, and also launch applications with as few privileges as possible.</p>
<p>4.12 Payment Mechanisms</p> <p>Major types of Electronic Payments are Credit Cards, Electronic cheques, Smart cards and Electronic purses.</p>

Question 1

Differentiate between the following:

- (a) *Data and Information*
- (b) *Role-based Access Control (RBAC) and Rules-based Access Control (RAC)*

Or

Briefly explain the two main approaches to establish access controls in Software Systems.

- (c) *Explicit Knowledge and Tacit Knowledge*
- (d) *Information and Knowledge*

Answer

- (a) The differences between Data and Information are as follows:

Data	Information
Data is raw and unorganized fact that needs to be processed.	When data is processed, organized, structured or presented in a given context so as to make it useful, it is called Information.
Data in itself is meaningless and is the lowest level of knowledge.	Information is the second level of knowledge.
Observations and recordings are done to obtain data.	Analysis of data is done to obtain information.

- (b) **Role-based Access Control (RBAC):** RBAC largely eliminates discretion when providing access to objects. Instead, administrators or automated systems place subjects into roles. Subjects receive only the rights and permissions assigned to those roles. RBAC uses a centrally administered set of controls to determine how subjects and objects interact. When an employee changes jobs, all previous access is removed, and the rights and permissions of the new role are assigned. RBAC enforces static constraints based on a user's role. It is the best system for an organization that has high turnover.

4.8 Information Technology

Rules-based Access Control (RAC): RAC takes into account the data affected, the identity attempting to perform a task, and other triggers governed by business rules. RAC uses specific rules that indicate what can and cannot happen between a subject and an object. A manager, for example, has the ability to approve his/her employees' hours worked. However, when s/he attempts to approve his/her own hours, a rule built into the application compares the employee record and the user, sees they are the same, and temporarily removes approval privilege. It is not necessarily identity based.

- (c) **Explicit knowledge:** Explicit knowledge is that knowledge which can be formalized easily and as a consequence is easily available across the organization. Explicit knowledge is articulated, and represented as spoken words, written material and compiled data. This type of knowledge is codified, easy to document, transfer and reproduce. For example - Online tutorials, Policy and procedural manuals.

Tacit knowledge: Tacit knowledge, on the other hand, resides in a few often-in just one person and hasn't been captured by the organization or made available to others. Tacit knowledge is unarticulated and represented as intuition, perspective, beliefs, and values that individuals form based on their experiences. It is personal, experimental and context-specific. It is difficult to document and communicate the tacit knowledge. For example - hand-on skills, special know-how, employee's experiences.

- (d) Differences between Information and Knowledge are given as follows:

Information	Knowledge
Information is piecemeal, fragmented and particular.	Knowledge is structured, coherent, and often universal.
Information is timely, transitory, and may even be short-lived.	Knowledge is of enduring significance.
Information is a flow of messages.	Knowledge is a stock, largely resulting from the flow, in the sense that the "input" of information may affect the stock of knowledge by adding to it, restructuring it, or changing it in any way.
Information is acquired by being told.	Knowledge can be acquired by thinking. Thus, new knowledge can be acquired without new information being received.

Question 2

Define the following:

- (a) *Business Information System*
- (b) *Business Process*
- (c) *Knowledge Management*
- (d) *eXtensible Business Reporting Language (XBRL)*

(e) *Online Analytical Processing (OLAP)*

Answer

- (a) **Business Information System:** Business Information Systems may be defined as system integrating business functions and information modules for establishing effective communication channels which are useful for making timely and accurate decisions and in turn contribute to organizational productivity and competitiveness.
- (b) **Business Process:** A Business Process is a collection of related, structured activities or tasks that produce a specific service or product (serve a particular goal) for a specific organization.
- (c) **Knowledge Management:** Knowledge Management encompasses both the content and the process of creating the content. It refers both to what is known and how it came to be known.
- (d) **eXtensible Business Reporting Language (XBRL):** XBRL is freely available international standards-based business reporting language developed by accountants for financial reporting.
- (e) **Online Analytical Processing (OLAP):** OLAP is a multi-dimensional analytical tool typically used in data mining, that gathers and process vast amounts of information into useful packets.

Question 3

What is an Information System? Discuss its components in detail.

Answer

Information System: An Information System (IS) is a combination of people, hardware, software, communication devices, network and data resources that processes (can be storing, retrieving, transforming information) data and information for a specific purpose. The system needs inputs from user (key in instructions and commands, typing, scanning) which will then be processed (calculating, reporting) using technology devices such as computers, and produce output (printing reports, displaying results) that will be sent to another user or other system via a network and a feedback method that controls the operation.

In general, any specific Information System aims to support operations, management and decision-making.

Components of Information System

The main aim and purpose of each Information System is to convert the data into information which is useful and meaningful. This process consists of four basic concepts:

- (i) People, hardware, software, and data are four basic resources of information systems;
- (ii) Human resources consist of end users and IT specialists; hardware resources involve machines and media; software resources consist of programs and procedures; and data

4.10 Information Technology

resources include data and knowledge base; and network resources include communications media and networks.

- (iii) A process is used to convert data into information for end users;
- (iv) Information processes consist of input, processing, output, storage, and control processes.

All components of information systems are mutually connected and cannot exist individually. The output could be in terms of printouts, reports, graphics; Input can be data, information and instructions; Processing may involve calculations, programming and storing; Controls could be related to decision-making and the feedback.

Question 4

Discuss Transaction Processing System (TPS).

Answer

Transaction Processing System (TPS) may be defined as a type of information system that collects, stores, modifies and retrieves the day-to-day data transactions of an enterprise. Archetypal examples of such systems would be used in an Airline Reservation Systems, Railway reservation by IRCT, Banking Systems, or the Accounting System of roughly any outsized company. These are designed to process transactions virtually instantly to ensure that customer data is available to the processes that require it. Most of the Transaction Processing Systems include one or additional of the following attributes:

- ◆ **Access Control-TPS:** Most Transaction Processing Systems come with access control to put a ceiling on users to only those allowed to accomplish so. Access Control ensures that people who are not authorized to use the system are not permissible to influence or transform the transaction process.
- ◆ **Equivalence-TPS:** Transactions are processed in the similar format every time to ensure that full effectiveness is achieved. The TPS Interfaces are designed to get hold of identical data for each transaction, despite the consequences of the source.
- ◆ **High Volume Rapid Processing-TPS:** TPS is designed to process transactions in an immediate to make confident that the transaction data is available to other users or processes that entail it. The instantaneous processing of transactions is noteworthy to the success of certain industry such as banking.
- ◆ **Trustworthiness-TPS:** A TPS system is designed to be robust and trustworthy. The system is capable to process transactions very rapidly, yet at the same time, conduct several checks to make certain that the data integrity is preserved.

Question 5

Discuss Office Automation Systems (OAS) in brief.

Answer

Office Automation System (OAS) is an amalgamation of hardware, software, and other resources used to smooth the progress of communication and augment efficiency. Office

automation refers to the use of computer and software to digitally generate, collect, store, manipulates, and relay office information needed for accomplishing basic tasks and goals.

In addition to capturing handwritten notes, it comprises of exchange of information; management of administrative documents; handling of numerical data; and meeting, planning and management of work schedules. Office Automation System takes into consideration the computer applications and other problem solving tool along with a database to transform input into output.

Office Automation is a widespread appearance that includes an all-embracing variety of applications of computer, communication and information technologies in office surroundings.

Question 6

Discuss Knowledge Management System (KMS).

Answer

Knowledge Management Systems (KMS) refers to any kind of IT system that stores and retrieves knowledge, improves collaboration, locates knowledge sources, mines repositories for hidden knowledge, captures and uses knowledge, or in some other way enhances the knowledge management process. KMS treats the knowledge component of any organization's activities as an explicit concern reflected in strategy, policy, and practice at all levels of the organization.

- ◆ Two broad categories of knowledge exist – **Explicit** and **Tacit**. Explicit Knowledge is formalized, articulated and written whereas Tacit Knowledge resides in a few often-in-just one person and has not been captured by the organization.
- ◆ Knowledge base is a special kind of database for knowledge management. It is an information repository that provides a means for information to be collected, organized, shared, searched and utilized. It can be either machine-readable or intended for human use.
- ◆ A Knowledge Discovery in databases system is a value-added intranet with facilities to search and identify captured knowledge, or identify experts who have the knowledge. The system will also help us establish contact with the expert and have a dialogue with them. It will then capture and make available the transcripts of such discussions, whether they be on chat, e-mail or discussion forums.

Question 7

Discuss Management Information System (MIS).

Answer

Management Information System (MIS) refers to the data, equipment and computer programs that are used to develop information for managerial use. It is an integrated system which provides accurate, timely and meaningful data for management planning, analysis and control to optimize the growth of the organization. Management Information Systems provide decision-makers with preselected types of information. MIS is generally in the form of computer-generated reports and usually generated from data obtained from transaction processing systems.

4.12 Information Technology

Airline reservations (seat, booking, payment, schedules, boarding list, special needs, etc.), Bank operations (deposit, transfer, withdrawal) electronically with a distinguish payment gateways, Integration of department with the help of contemporary software's like ERP, and Logistics management application to streamline the transportation system etc. are some of the examples of MIS.

Question 8

Discuss Decision Support Systems (DSS). Discuss its components in detail.

Or

Explain the different components of Decision Support Systems.

Answer

A **Decision Support System (DSS)** is a computer-based information system that supports business or organizational decision-making activities. DSSs serve the management, operations and planning levels of an organization (usually mid and higher management) and help to make decisions, which may be rapidly changing and not easily specified in advance. DSS can be either fully computerized, human or a combination of both. A properly designed DSS may be defined as an interactive software-based system intended to help decision makers compile useful information from raw data, documents, personal knowledge, and/or business models to identify and solve problems and make decisions. DSS are there to facilitate a manager in making operational decisions, but the ultimate burden of responsibility lies with the manager. Managers can sometimes be over-optimistic in their expectations of a DSS and develop an unrealistic reliance on the system.

Two types of planning languages that are commonly used in DSS are: **General-purpose Planning Languages** and **Special-purpose Planning Languages**. These are discussed below:

- **General-purpose planning languages** that allow users to perform many routine tasks, for example; retrieving various data from a database or performing statistical analyses. The languages in most electronic spreadsheets are good examples of general-purpose planning languages. These languages enable user to tackle a broad range of budgeting, forecasting, and other worksheet-oriented problems.
- **Special-purpose planning languages** are more limited in what they can do, but they usually do certain jobs better than the general-purpose planning languages. Some statistical languages, such as SAS and SPSS, are examples of special purpose planning languages.

The components of DSS are as follows:

- (a) **The user:** The user is usually a manager with an unstructured or semi-structured problem to solve and may be at management - level of an organization.

- (b) **One or more databases:** Databases contain both routine and non-routine data from both internal and external sources.
- (c) **Model Base:** Model base is the brain of the DSS as it performs data manipulations and computations with the data provided to it by the user and the database. The planning language in DSS allows the user to maintain a dialogue with the model base.

Question 9

What do you understand by the term “Executive Information System (EIS)”. Discuss its components, in detail.

Answer

An **Executive Information System (EIS)** is the nature of Information System used by executives to access and administer the data they entail to make informed business decisions. The EIS in itself is not an instrument, but rather, an infrastructure within a company. It may be defined as just not as a piece of hardware or software, but an infrastructure that supplies to a firm's executives the up-to-the-minute operational data, gathered and sifted from various databases. EIS links data from various sources both internal and external to provide the amount and kind of information executives find useful. These systems are designed for top management; easy to use; present information in condensed view; access organization's databases and data external to the organization.

The typical information mix presented to the executive may include financial information, work in process, inventory figures, sales figures, market trends, industry statistics, and market price of the firm's shares.

Components of an Executive Information Systems (EIS) are as follows:

Component	Description
Hardware	Includes Input data-entry devices, CPU, Data Storage files and Output Devices.
Software	Includes Text base software, Database, and Graphic types such as time series charts, scatter diagrams, maps, motion graphics, sequence charts, and comparison-oriented graphs (i.e., bar charts) Model base.
User Interface	Includes hardware (physical) and software (logical) components by which people (users) interact with a machine. Several types of interfaces can be available to the EIS structure, such as scheduled reports, questions/answers, menu driven, command language, natural language, and input/output.
Telecommunication	Involves transmitting data from one place to another in a reliable networked system.

Question 10

Discuss Customer Relationship Management (CRM).

Answer

Customer Relationship Management (CRM) may be defined as a business process in which client relationships; customer loyalty and brand value are built through marketing strategies and activities. CRM allows businesses to develop long-term relationships with established and new customers while helping modernize corporate performance. CRM incorporates commercial and client-specific strategies via employee training, marketing planning, relationship building and advertising. The main objective is to retain as much loyal customers as one can.

To accomplish with CRM, companies need to match products and campaigns to prospect elegantly the customer life cycle. CRM encompasses the function and responsibilities of those employees who directly work with customers. CRM establishes the benefits of generating customer loyalty, raising a market intelligence enterprise, and an integrated relationship. Preserving existing customers and providing enhanced services to accomplish the loyalty is expressed as CRM. CRM applications smoothen the progress to capture, consolidate, analysis, and enterprise-wide dissemination of data from existing and potential customers. CRM can be considered as an amalgamation of people, process and systems rather than just IT application.

Question 11

What is Supply Chain Management (SCM)? Discuss its components.

Answer

Supply Chain Management (SCM) is a chain that starts with customers and ends with customers. Supply Chain Management may be defined as the process of planning, implementing and controlling the operations of the supply chain with the purpose of satisfying the customer's requirement as efficiently as possible. Supply Chain spans all movement and storage of raw materials, work-in-process, inventory and finished goods from the point of origin to the point of consumption.

Components of SCM: The main elements of a supply chain are as follows:

- (a) **Procurement/Purchasing** – It begins with the purchasing of parts, components, or services. Procurement must ensure that the right items are delivered in the exact quantities at the correct location on the specified time schedule at minimal cost. The key issue in procurement is how one goes about selecting and maintaining a supplier, which can be approached from two directions. The first concentrates on how a firm might evaluate a potential supplier whereas the second is how a firm evaluates those businesses that are already suppliers to an operation.
- (b) **Operations** – The second major element of SCM is Operations. Having received raw materials, parts, components, assemblies, or services from suppliers, the firm must transform them and produce the products or the services that meet the needs of its consumers. It must conduct this transformation in an efficient and effective manner for the benefit of SCM system.

- (c) **Distribution** – The third element of the SCM system is distribution. Distribution involves several activities - transportation (logistics) of goods across the entire supply chain, warehousing, and CRM.

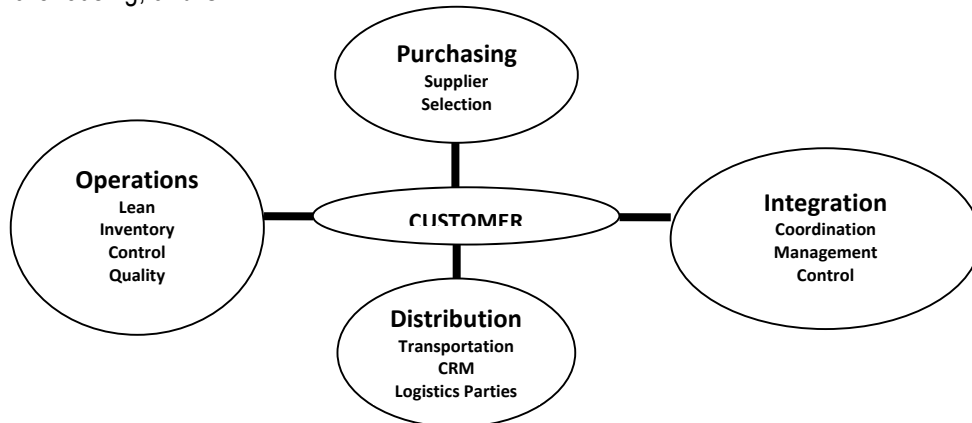

Core elements of a SCM

- (d) **Integration** - The last element of SCM is the need for integration. It is critical that all participants in the service chain recognize the entirety of the service chain. The impact of the failure to adopt a system-wide perspective - that is, examining the totality of the chain can significantly increase costs and destroy value.

Question 12

What is HRMS? Discuss its key modules.

Answer

A Human Resource Management System (HRMS) is a software application that coalesce many human resources functions together with benefits like administration, payroll, recruiting and training, performance analysis and assessment into one parcel.

Key Modules of HRMS are as follows:

- ◆ **Workforce Management:** Integrated across the strategic Human Capital Management (HCM) solution; Workforce Management provides powerful tools to effectively manage labour rules, ensure compliance, and control labour costs and expenses.
- ◆ **Time and Attendance Management:** The time and attendance module gathers standardized time and work related efforts. The most advanced modules provide broad flexibility in data collection methods, labor distribution capabilities and data analysis features. Cost analysis and efficiency metrics are the primary functions.
- ◆ **Payroll Management:** This module of the system is designed to automate manual payroll functions and facilitate salary, deductions, calculations etc.; eliminates errors and free up HR staff for more productive tasks. Data is generally fed from the human resources and time keeping modules to calculate automatic deposit and manual cheque writing

4.16 Information Technology

capabilities. This module can encompass all employee-related transactions as well as integrate with existing financial management systems.

- ◆ **Training Management:** Training programs can be entered with future dates which allow managers to track progress of employees through these programs, examine the results of courses taken and reschedule specific courses when needed. The module tracks the trainer or training organization; costs associated with training schedules, tracks training locations, required supplies and equipment and registered attendees.
- ◆ **Compensation Management:** Compensation Management is more than just the means to attract and retain talented employees. In today's competitive labor market, organizations need to fully leverage their human capital to sustain a competitive position. This requires integrating employee processes, information and programs with organizational processes and strategies to achieve optimal organizational results.
- ◆ **Recruitment Management:** This module helps in hiring the right people with the right target skills. This module includes processes for managing open positions/requisitions, applicant screening, assessments, selection and hiring, correspondence, reporting and cost analysis.
- ◆ **Personnel Management:** The personnel management module comprises of HR master-data, personnel administration, recruitment and salary administration.
- ◆ **Organizational Management:** Organizational Management module includes organizational structure, staffing schedules and job description.
- ◆ **Employee Self Service (ESS):** The Employee Self Service module allows employees to query HR related data and perform some Human Resource transactions over the system. For example - Employees may query their attendance record from the system without asking the information from HR personnel.
- ◆ **Analytics:** The Analytics module enables organizations to extend the value of an HRMS implementation by extracting HR related data for use with other business intelligence platforms. For example, organizations combine HR metrics with other business data to identify trends and anomalies in headcount in order to better predict the impact of employee turnover on future output.

Question 13

Discuss Core Banking System (CBS).

Answer

Core Banking System (CBS) may be defined as the set of basic software components that manage the services provided by a bank to its customers through its branches (branch network). The absolute bank's branches access applications from centralized data centers. All transactions budge through core systems, which, at an absolute minimum, must remain running and responsive during business hours. Increasingly, these systems are running 24x7 to support

Internet banking, global operations, and real time transactions via ATM, Internet, phone, and debit card.

The various elements of core banking include making and servicing loans; opening new accounts; processing cash deposits and withdrawals; processing payments and cheques; calculating interest; Customer Relationship Management (CRM) activities; managing customer accounts; establishing criteria for minimum balances, interest rates, number of withdrawals allowed and so on; establishing interest rates; and maintaining records for all the bank's transactions.

Normal core banking functions include deposit accounts, loans, mortgages and payments. Banks make these services available across multiple channels like ATMs, Internet banking, and branches. Examples of major core banking products include Infosys' Finacle, Nucleus FinnOne and Oracle's Flexcube application (from their acquisition of Indian IT vendor i-flex).

Question 14

What do you understand by Accounting Information System (AIS)? Also discuss its key elements.

Answer

Accounting Information System (AIS) is defined as a system of collection, storage and processing of financial and accounting data that is used by decision makers. An AIS is generally a computer-based method for tracking accounting activity in conjunction with information technology resources. The resulting statistical reports can be used internally by management or externally by other interested parties including investors, creditors and tax authorities. Accounting information system takes into consideration different aspects, which are composed of smaller subsystems, which help an organization in achieving its goal. The different sub components in AIS include Budgeting and Planning, Expenses Management, Revenue Management, Cash and Treasury Management, Accounting software, Electronic Banking, Activity-based Management, Payroll etc.

The key elements that compose the typical Accounting Information System are as follows:

- (i) **People:** AIS helps various system users that include accountants, consultants, business analysts, managers, chief financial officers and auditors etc. from different departments within a company to work together. With well-designed AIS, everyone within an organization who is authorized to do so can access the same system and get the same information. AIS also simplify getting information to people outside of the organization when necessary.
- (ii) **Procedure and Instructions:** These include both manual and automated methods for collecting, storing, retrieving and processing data.
- (iii) **Data:** It refers to the information pertinent to the organization's business practices that may include sales orders, customer billing statements, sales analysis reports, purchase requisitions, vendor invoices, check registers, general ledger, inventory data, payroll

4.18 Information Technology

information, timekeeping, tax information etc. This data can then be used to prepare accounting statements and reports such as accounts receivable aging, depreciation/amortization schedules, trial balance, profit and loss, and so on.

- (iv) **Software:** These are the computer programs that provide quality, reliability and security to the company's financial data that may be stored, retrieved, processed and analyzed. Managers rely on the information it outputs to make decisions for the company, and they need high-quality information to make sound decisions.
- (v) **Information Technology Infrastructure:** This include hardware such as personal computers, servers, printers, surge protectors, routers, storage media, and possibly a backup power supply used to operate the system. The hardware selected for AIS must be compatible with the intended software.
- (vi) **Internal Controls:** These are the security measures such as passwords or as complex as biometric identification to protect sensitive data against unauthorized computer access and to limit access to authorized users. Internal controls also protect against computer viruses, hackers and other internal and external threats to network security.

Question 15

Write a short note on the following:

- (a) *Artificial Intelligence*
- (b) *Just-In-Time (JIT)*
- (c) **Nucleus FinnOne**
- (d) **Data Mining**

Answer

- (a) **Artificial Intelligence (AI)** is the vicinity of computer science focusing on creating machines that can fit into place on behaviors that humans regard as intelligent. It is a research field that studies how to comprehend the intelligent human behaviors on a computer. The decisive objective of AI is to make a computer that can discover, sketch, and crack problems in parallel. The subject of artificial intelligence spans a wide horizon dealing with various kinds of knowledge representation schemes, different techniques of intelligent search, various methods for resolving uncertainty of data and knowledge, different schemes for automated machine learning and many others. Expert systems, Pattern Recognition, Natural language processing, and many others are some of the various purposes on which AI may be applied.
- (b) JIT is a philosophy of continuous improvement in which non-value-adding activities (or wastes) are identified and removed for the purposes of:
 - Reducing Cost
 - Improving Quality

- Improving Performance
- Improving Delivery
- Adding Flexibility
- Increase Innovativeness

When the JIT principles are implemented successfully, significant competitive advantages are realized. JIT principles can be applied to all parts of an organization: order taking, purchasing, operations, distribution, sales, accounting, design, etc.

- (c) **Nucleus FinnOne**: *The Nucleus FinnOne is a banking suite, made and marketed by India-based Company Nucleus software, and comes with a wide variety of integrated applications that cover different aspects of global web banking. These applications support banks and financial solution companies in dealing with assets, liabilities, core financial accounting and customer service. The solution is wholly focused on banking and financial services spanning across solutions in the areas of Retail and Corporate Banking, Cash Management, Relationship Banking, Financial CRM, Credit Risk & Appraisal, Enterprise Application Integration (EAI), Internet Banking, Data warehousing and Analytics.*

- (d) **Data Mining**: *Main points about data mining are as under –*

It is one of the business intelligence tool that involves using statistical, artificial intelligence, and related techniques to mine through large volumes of data and providing knowledge without users even having to ask specific questions.

The objective is to provide interesting and useful information to users by design even without their querying.

Data Mining involves data analysis for discovering useful patterns that are hidden in large volume of diverse data. For Example: Market segmentation - identify common characteristics of customers who buy same products.

OLAP (Online Analytical Processing) is a multi-dimensional analytical tool typically used in data mining, that gathers and process vast amounts of information into useful packets.

Question 16

What are the possible ways to make payments electronically?

Answer

Major types of Electronic Payments are as follows:

- A. **Credit Cards**: In a credit card transaction, the steps involved are authorization, batching, clearing and funding. The consumer presents preliminary proof of his ability to pay by presenting his credit card number to the merchant. The merchant can verify this with the bank, and create a purchase slip for the consumer to endorse. The merchant then uses

4.20 Information Technology

this purchase slip to collect funds from the bank, and, on the next billing cycle, the consumer receives a statement from the bank with a record of the transaction.

- B. Electronic Cheque:** Credit card payments are popular for commerce on the Internet. However, FSTC and CyberCash are two systems that let consumers use electronic cheques to pay Web merchants directly. **Financial Services Technology Corporation (FSTC)** is a consortium of banks and clearing houses that has designed an electronic cheque that is initiated electronically, and uses a digital signature for signing and endorsing. By **CyberCash**, electronic cheque functions as a message to the sender's bank to transfer funds, and, like a paper cheque, the message is given initially to the receiver who, in turn, endorses the cheque and presents it to the bank to obtain funds.
- C. Smart Cards:** Smart cards are any pocket sized card with embedded integrated circuits. Smart cards can provide identification authentications, data storage and application processing. Smart cards may serve as a credit or ATM cards, Fuel cards, mobile phone SIMs, access-control cards, public transport or public phone payment cards etc. on the card. Contact cards, Contactless cards and Combi/Hybrid Cards are the three types of Smart Cards.
- D. Electronic Purses:** Electronic Purse Card is very similar to a pre-paid card. Bank issues a stored value card to its customer, the customer can then transfer value from his/her account to the card at an ATM, a personal computer, or a specially equipped telephone. While making purchases, customers pass their cards through a vendor's Point of Sale terminal. Validation is done through a Personal Identification Number (PIN Number). Once the transaction is complete, funds are deducted directly from the cards and transferred to the vendor's terminal. When the value on a card is spent, consumers can load additional funds from their accounts to the card.

Question 17

What is an Expert System? Discuss its key components.

Answer

An **Expert System (ES)** is a computerized information system that allows non-experts to make decisions comparable to those of an expert. The aim of the expert system is to have a team of seasoned specialists holding industry-wide experience who further spread across implementations like in Defense, Government, Finance, Telecom, and Engineering sectors.

Components of an Expert System are as follows:

- (a) Knowledge Base:** This includes the data, knowledge, relationships, rules of thumb (heuristics), and decision trees used by experts to solve a particular problem. A knowledge base is the computer equivalent of all the knowledge and insight that an expert or group of experts develop through years of experience in their field. The knowledge base of expert system encloses both realistic and heuristic knowledge. Realistic knowledge is that knowledge of the job domain that is extensively shared, characteristically found in

textbooks or journals whereas heuristic knowledge is the fewer rigorous, extra empirical, supplementary judgmental knowledge of performance.

- (b) **Database of Facts:** This holds the user's input about the current problem. The user may begin by entering as much as they know about the problem or the inference engine may prompt for details or ask whether certain conditions exist. Gradually a database of facts is built up which the inference engine uses to come to a decision. The quality and quantity of data gained from the user influences the reliability of the decision.
- (c) **Inference Engine:** This program contains the logic and reasoning mechanisms that simulate the expert logic process and deliver advice. It uses data obtained from both the knowledge base and the user to make associations and inferences, form its conclusions, and recommend a course of action.
- (d) **Explanation facility:** This facility provides the user with an explanation of the logic the Expert System used to arrive at its conclusion.
- (e) **User Interface:** This program allows the user to design, create, update, use and communicate with the expert system.

Question 18

What is the difference between electronic cheque and paper cheque?

Answer

An e-cheque is an instrument where one person issues it to pay another person but there is no paper involved. Everything is electronic. An electronic cheque can be protected against any fraud by encoding sender's account number with the bank's public key thereby not revealing the sender's account number to the merchant. As with the SET protocol, digital certificates can be used to authenticate the payer, the payer's bank, and bank account. However, no such encoding of sender's account number is possible in case of paper cheque. E-cheque are faster and more convenient than paper cheque. It is environmentally friendly too.

Question 19

Explain the pre-requisites of ACID Test for any Transaction Processing System (TPS).

Answer

The ACID Test refers to the following prerequisites for any Transaction Processing System (TPS).

- **Atomicity:** This means that a transaction is either completed in full or not at all. TPS systems ensure that transactions take place in their entirety.
- **Consistency:** TPS systems exist within a set of operating rules or integrity constraints. For Example - If an integrity constraint states that all transactions in a database must have a positive value, any transaction with a negative value would be refused.

4.22 Information Technology

- **Isolation:** Transactions must appear to take place in seclusion. For example, the funds cannot be credited to an account before they are debited from another.
- **Durability:** Once transactions are completed they cannot be undone. To ensure this, a log will be created to document all completed transactions.

Question 20

You are in-charge of Customer Relationship Management (CRM). Describe the relevance of Old Pareto Rule “80/20 Rule”.

Answer

Pareto Rule emphasizes that most organizations find that approximately 20% of their customer base generates 80% of the profits. It is merely based on the philosophy that indicates that old trustworthy customers are most lucrative and help in generating profits.

Question 21

What do you mean by ‘Frame Based Expert System’? Also, explain the various components of Executive Information System (EIS).

Answer

Frame Based Expert System: *These systems organize all the information (data, description, rules etc.) about a topic into logical units called Frames, which are like linked records in data files. Rules are then established about how to assemble or inter-relate the frames to meet the user’s needs.*

The components of an Executive Information System (EIS) are as follows:

- **Hardware:** *This includes Input data-entry devices, CPU, Data Storage files and Output Devices.*
- **Software:** *This includes Text base software, Database, and Graphic types such as time series charts, scatter diagrams, maps, motion graphics, sequence charts, and comparison-oriented graphs (i.e., bar charts), Model base.*
- **User Interface:** *This includes hardware (physical) and software (logical) components by which people (users) interact with a machine. Several types of interfaces can be available to the Executive Information System structure, such as scheduled reports, questions/answers, menu driven, command language, natural language, and input/output.*
- **Telecommunication:** *This involves transmitting data from one place to another in a reliable networked system.*

Question 22

Explain the ‘Dashboards’ and ‘Scorecards’ as tools of Business Intelligence.

Answer

Dashboards: This involves using the information gathered from the data warehouse and making it available to users as snapshots of many different things with the objective of getting response to the query: "Tell me a lot of things, but without too much effort". Dashboards are flexible tools that can be bent into as many different shapes as per user requirements. It includes a collection of graphs, reports, and KPIs (Key Performance Indicators) that can help monitor such business activities as progress on a specific initiative.

Scorecards: This involves providing a visual representation of the enterprise strategy by taking critical metrics and mapping them to strategic goals throughout the enterprise. Scorecards offer a rich, visual gauge to display the performance of specific initiatives, business units, or the enterprise and the individual goals in the context of larger enterprise strategy. Scorecards distil information into a small number of metrics and targets and provide users with an at-a-glance perspective of information. A scorecard has a graphical list of specific, attainable strategic milestones, combined with metrics that serve as benchmarks. Specific measures on how well the company has performed specified activities are linked in the scorecard with graphical display highlighting the status of each goal.

Question 23

You are requested to implement the Online Transaction Processing in an e-commerce environment. Briefly explain step by step Online Transaction Processing in such environment.

Answer

A typical On-line transaction can be viewed as follows:

- ◆ **Advertising:** The company communicates its products and services (catalogue);
- ◆ **Offering:** The company offers specific goods and services;
- ◆ **Selling:** The company agrees with the customer on the content of a specific order;
- ◆ **Billing:** The company produces the invoice;
- ◆ **Paying:** The buyer pays the seller by giving a payment instruction;
- ◆ **Matching:** The seller matches the payment information (the authorization results and the actual crediting of account) with the orders and feeds the result into the back-office;
- ◆ **Delivering:** The seller delivers to the buyer; and
- ◆ **Resolving:** The seller and buyer try to resolve delivery or payment issues related to the purchase.

Question 24

Briefly describe the four stages of processing Credit Card transactions.

Answer

Four stages followed for processing of Credit Card Transactions:

Stage 1: Authorization – This is the first step in processing a credit card. After a merchant swipes the card, the data is submitted to merchant's bank, called an acquirer, to request authorization for the sale. The acquirer then routes the request to the card-issuing bank, where it is authorized or denied, and the merchant can process the sale.

Stage 2: Batching – This is the second step in processing a credit card. At the end of a day, the merchant reviews all the day's sales to ensure they were authorized and signed by the cardholder. It then transmits all the sales at once, called a batch, to the acquirer to receive payment.

Stage 3: Clearing – This is the third step in processing a credit card. After the acquirer receives the batch, it sends it through the card network, where each sale is routed to the appropriate issuing bank. The issuing bank then subtracts its interchange fees, which are shared with the card network, and transfers the remaining amount through the network back to the acquirer.

Stage 4: Funding – This is the fourth and final step in processing a credit card. After receiving payment from the issuer, minus interchange fees, the acquirer subtracts its discount fee and sends the remainder to the merchant. The merchant is now paid for the transaction, and the cardholder is billed.

Question 25

Describe how the Business Community is benefitted by adopting Information Technology based CRM process.

Answer

CRM can be considered as an amalgamation of people, process and systems rather than just IT application. Business Community is benefitted by adopting Information Technology based Customer Relationship Management (CRM) process in following ways:

- **CRM applications smoothen the process to capture, consolidate, analyze, and business enterprise-wide dissemination of data from existing and potential customers.**
- **CRM allows businesses to develop long-term relationships with established and new customers while helping modernize corporate performance. CRM incorporates commercial and client-specific strategies via employee training, marketing planning, relationship building and advertising.**
- **CRM establishes the benefits of generating customer loyalty, raising a market intelligence enterprise, and an integrated relationship. Preserving existing**

customers and providing enhanced services to accomplish the loyalty is expressed as CRM.

- *CRM helps to form business strategy to handle business challenges like, declining revenue, cut-off in the profit margin, costs occurred due to lost customers etc.*
- *CRM provides a single integrated enterprise view of the customer thus providing proficiency to the business enterprises to recognize all the services/products the customer had fetched from the organization and thus being able to recognize the buying behavior/pattern of the customer.*

Exercise

1. *Discuss System and its components?*
2. *What are the various stages involved in ERP implementation?*
3. *Discuss the Principle of Least Privilege in Information Security.*
4. *With are the various steps involved in an online payment transaction?*
5. *What are the different types of Smart Cards?*
6. *Discuss importance of Access and Privilege controls in order to safeguard software systems.*
7. *How a credit card is processed?*
8. *What are the different types of Expert Systems?*
9. *What do you understand by the term "Business Intelligence"? Discuss some of the business intelligence tools.*

5

Business Process Automation through Application Software

5.1 Introduction

The speed of automation of all activities, whether they be connected to business directly or not has surprised the stakeholders of enterprises, who are affected by such computerization. In our professional work, we realize that our daily jobs have been changed with the help of technology and automated systems. For example-Attendance marking and Tracking systems. Any enterprise located in any remote corner can make their products or services available to anyone, anywhere at any time. New technologies are getting developed due to large scale computerization, decreasing costs of storing data and increasing speed of internet. Emerging technologies such as virtualization, grid computing and cloud delivery model are enabling technology. However, the level of automation needs to be controlled considering the inherent risks of technology.

5.2 Classification of Business Applications

Business Application is defined as a computer program used to fulfill a person's need for regular occupation or commercial activities like keeping track of inventory levels, checking for bank account balances, checking status of delivery of goods dispatched and all other business activities.

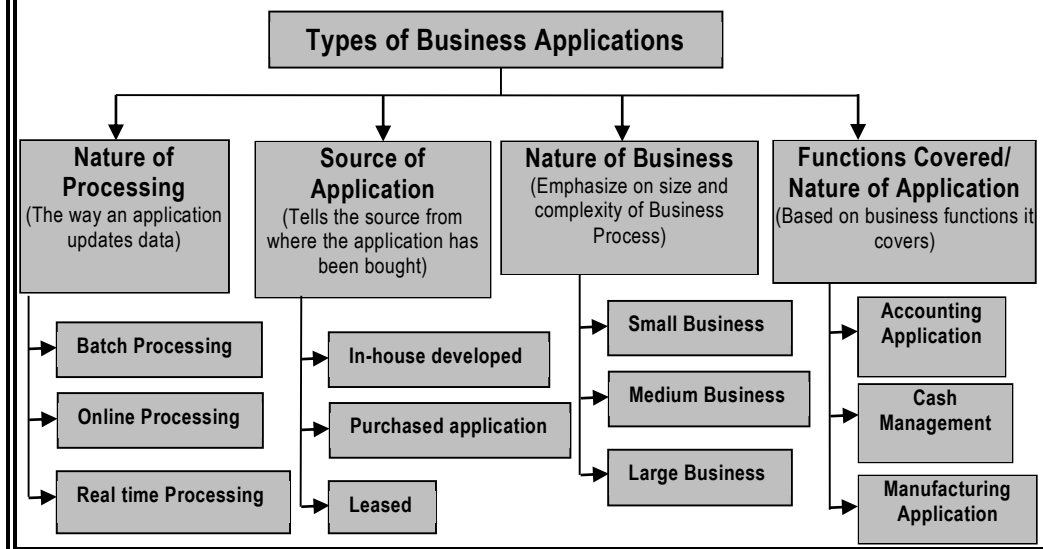

5.2.1 Applications based on Nature of Processing
<ul style="list-style-type: none"> • Batch Processing - It is defined as a processing of large set of data in a specific way, automatically, without needing any user intervention. The data is first collected, during a work day, for example, and then batch-processed, so all the collected data is processed in one go. • Online Processing - Data is processed immediately while it is entered, the user usually only has to wait a short time for a response. (Example: games, word processing, booking systems). Interactive or online processing requires a user to supply an input. Interactive or online processing enables the user to input data and get the results of the processing of that data immediately. • Real-time Processing - Real time processing is a subset of interactive or online processing. Input is continuously, automatically acquired from sensors, for example, which is processed immediately in order to respond to the input in as little time as possible. After the system is finished responding, it reads the next set of input data immediately to process that.
5.2.2 Applications based in Source of Application
<ul style="list-style-type: none"> • Custom-built Application: Customization involves additional coding while configuration is based on settings which are inputted by the user. Example – Billing, Inventory, Attendance etc. • Packaged Software: These are the standard applications which are not free but are licensed. Customization to suit business requirements may or may not be allowed. For Example -Tally, Oracle 9i, etc. • Leased application: A new method for getting applications is being used today, i.e. leased applications, where user pays fixed rent for using the application for agreed terms.
5.2.3 Applications based on Size and Complexity of Business
<ul style="list-style-type: none"> • Small and Medium Enterprise (SME) business: The best software for small and medium businesses is software designed to help them to run their operations better, cut costs and replace paper processes. The most popular software packages include accounts, office productivity, email and communications, but nowadays, most business activities can be improved through desktop or web-based applications. • Large Business: The business tools that tend to be favored by larger businesses include CRM, for recording customer information and finding out trends in buying habits; and sales force automation, which helpful for organizing and managing sales teams and leads. Business may also choose to use human resources software; business intelligence and dashboard tools; database management systems; and enterprise resource planning and supply chain management tools.

5.2.4 Business Applications based on Nature of Application
We shall restrict our discussion to business applications on the basis of functions covered. Some of the business applications based on nature of application are Accounting application, Office Management Software, Compliance Applications, Customer Relationship Management Software, Management Support Software, ERP Software, Product Lifecycle Management Software, Logistics Management Software, Legal Management Software and Industry Specific Applications.
5.3 Business Process Automation
Business Process: It is a set of activities that are designed to accomplish specific organizational goals. Business Process Automation (BPA) is a strategy to automate business processes so as to bring benefit to enterprise in terms of cost, time and effort.
5.3.1 Objectives of BPA
Confidentiality, Integrity, Availability and Timeliness are the objectives of BPA.
5.3.2 Why BPA?
Following are the primary reasons for automation by enterprises: <ul style="list-style-type: none">◆ Reducing the Impact of Human Error.◆ Transforming Data into Information.◆ Improving performance and process effectiveness.◆ Making users more efficient and effective.◆ Making the business more responsive.◆ Improving Collaboration and Information Sharing.◆ Cost Saving.◆ To remain competitive.◆ Fast service to customers.
5.3.3 How to go about BPA?
The steps to go about implementing business process automation are given as follows: Step 1: Define why we plan to implement a BPA? Step 2: Understand the rules/regulation under which it needs to comply with? Step 3: Document the process, we wish to automate. Step 4: Define the objectives/goals to be achieved by implementing BPA. Step 5: Engage the business process consultant. Step 6: Calculate the ROI for project. Step 7: Development of BPA. Step 8: Testing the BPA.

<p>TALLY, SAP R/3, MS Office Applications, Attendance systems, Vehicle Tracking Systems , Automated Toll Collection Systems, Department Stores System, Travel Management Systems etc. are some of the applications that help entity to achieve Business Process Automation.</p>
<p>5.4 Information Processing</p>
<p>Information may be defined as processed data, which is of value to the user and is necessary for decision making and survival of an entity as success of business depends upon making right decisions at the right time on the basis of the right information available. The effort to create information from raw data is known as Information Processing. Classification of information is based on level of human or computer intervention – Manual Information Processing cycle and Computerized Information Processing Cycle.</p>
<p>5.5 Delivery Channels</p>
<p>Delivery channels refer to the mode through which information or products are delivered to users. For example:</p>
<p>Delivery Channels for Information: Include Intranet, E-mail, Internal newsletters and magazines; Staff briefings, meetings and other face-to-face communications methods; Notice boards in communal areas; Manuals, guides and other printed resources; Hand-held devices (PDAs, etc.); and Social networking sites like Facebook, WhatsApp etc.</p>
<p>Delivery Channels for Products: Include Traditional models, brick and mortar type; Buying from a shop; Home delivery of products; Buying from a departmental store; and Buying online, getting home delivery and making cash payment on delivery etc.</p>
<p>5.5.1 Importance</p>
<p>It is important to have proper and accurate delivery channels for information or product distribution and to consider each of these channels while planning; an overall information management and communications strategy are required.</p>
<p>5.5.2 Information Delivery Channel: How to choose one?</p>
<p>When choosing appropriate delivery channels, one should understand staff needs & environment. It should be more than just the intranet. Further, traditional channel need to be formalized.</p>
<p>5.5.3 Product Delivery Channels: How to choose one?</p>
<p>The customers have moved from purchase of physical books to e-books. This shift has forced business to strategize their delivery channels.</p>

5.6 Controls in BPA
To ensure that all information that is generated from system is accurate, complete and reliable for decision making, there is a requirement for proper controls. Control is defined as policies, procedures, practices and organization structure that are designed to provide reasonable assurance that business objectives are achieved and undesired events are prevented or detected and corrected.
5.6.1 Control Objectives
Major control objectives are - Authorization, Completeness, Accuracy, Validity, Physical Safeguards and Security, Error Handling and Segregation of Duties. The controls are used to Protect, Detect or Correct unlawful events. <ul style="list-style-type: none">◆ Preventive Control: Those, which prevent occurrence of an error/fraud, say security guards.◆ Detective Control: Those, which capture an error, say audit trail.◆ Corrective Control: Those, which correct an error or reduce the loss due to error/risk, say insurance policy.
5.6.2 Information Systems' Controls
Managerial Controls - The controls at this level provide a stable infrastructure in which IS can be built, operated, and maintained on a day-to-day basis. Application Controls - Application controls are the controls on the sequence of processing events. These controls cover all phases of data right from data origination to its final disposal. Application controls cover transactions as they recorded in each stage of processing into master - parameter and transaction files and include controls relating to transmission and distribution of output through display, electronic media or printed reports. The two are well explained in below pages. Communication Controls under Application Controls deal with Physical Component Controls like Transmission Media (Guided and Unguided Media), Flow Controls (Simplex, Duplex etc.), Topological Controls (Star, Tree, Ring, Bus). The concept of these is well explained in detail in Chapter - 3 of the study material.
5.7 Emerging Technologies
Various emerging technologies/concepts are given in the following sections:
5.7.1 Network Virtualization
In Information Technology, Virtualization is the process of creating logical computing resources from available physical resources. This is accomplished using virtualization software to create a layer of abstraction between workloads and the underlying physical hardware.

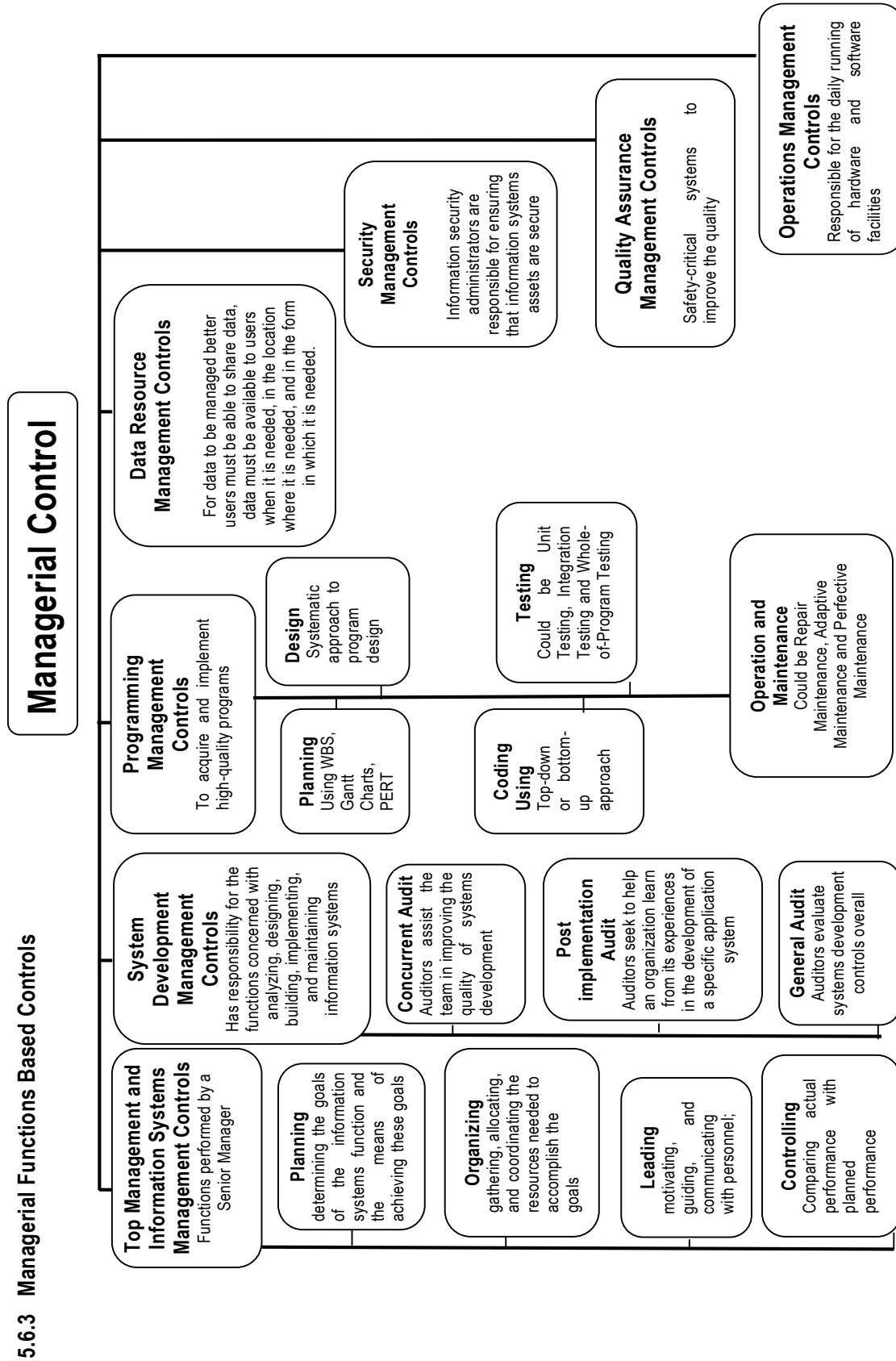

Types of Managerial Controls and their Objectives

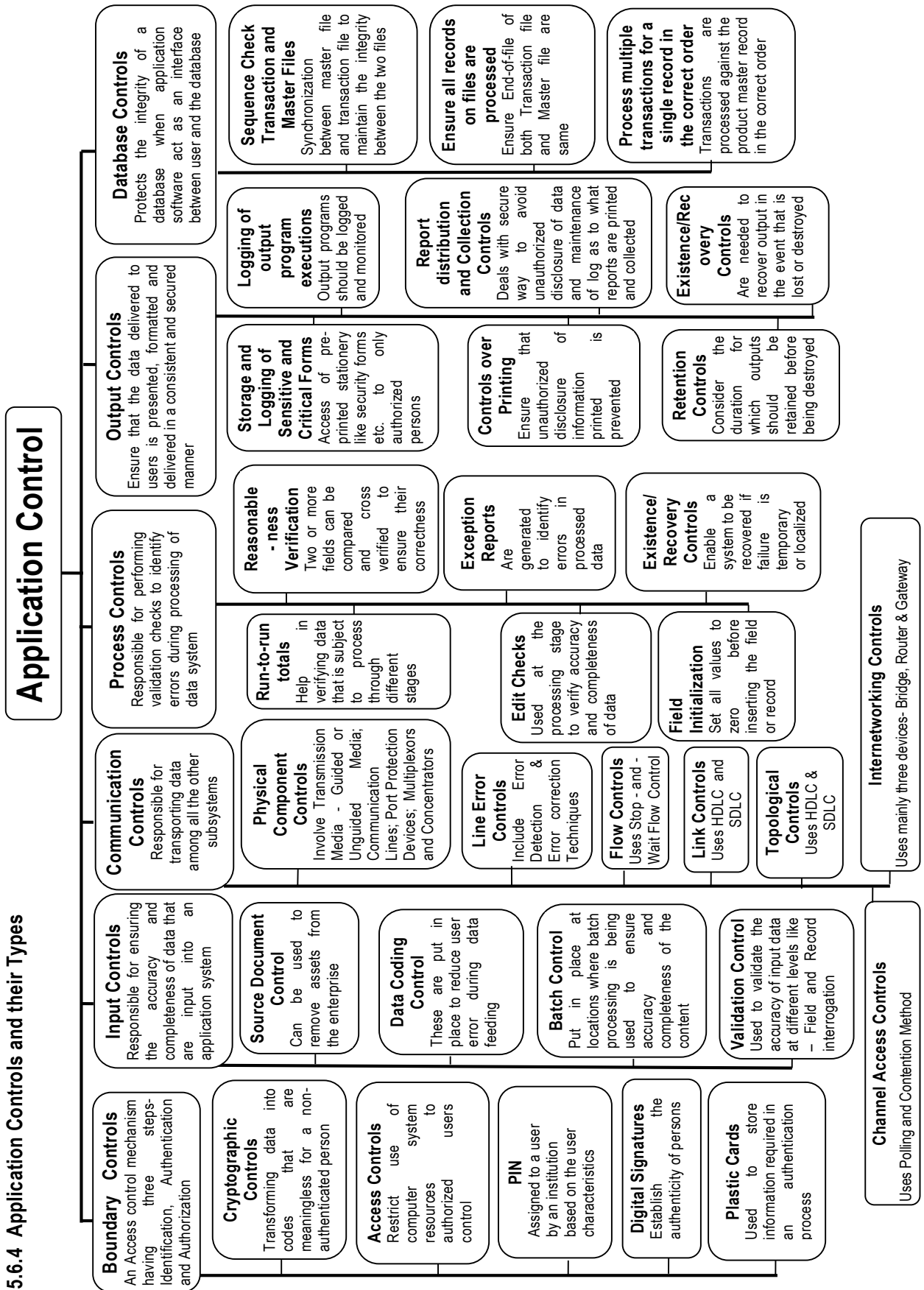

Types of Application Controls and their Objectives

5.7.2 Grid Computing
<p>In an ideal Grid Computing System, every resource is shared, turning a computer network into a powerful supercomputer. Every authorized computer would have access to enormous processing power and storage capacity. A grid computing system can be as simple as a collection of similar computers running on the same operating system or as complex as inter-networked systems comprised of every computer platform we can think of.</p>
5.7.3 Cloud Computing
<p>Cloud Computing is the use of various services, such as software development platforms, servers, storage, and software, over the Internet, often referred to as the "cloud." The common Cloud Computing Service Models are Software as a Service (SaaS), Platform as a Service (PaaS) and Infrastructure as a Service (IaaS).</p>

Question 1

What are the objectives of Business Process Automation (BPA)?

Answer

The success of any business process automation shall only be achieved when BPA ensures:

- ◆ **Confidentiality:** To ensure that data is only available to persons who have right to see the same;
- ◆ **Integrity:** To ensure that no un-authorized amendments can be made in the data;
- ◆ **Availability:** To ensure that data is available when asked for; and
- ◆ **Timeliness:** To ensure that data is made available in at the right time.

To ensure that all the above parameters are met, BPA needs to have appropriate internal controls put in place.

Question 2

Differentiate between Manual Information Processing Cycle and Computerized Information Processing Cycle.

Answer

Manual Information Processing Cycle	Computerized Information Processing Cycle
Systems where the level of manual intervention is very high. For example- Evaluation of exam papers, teaching and operations in operation theatres.	Systems where computers are used at every stage of transaction processing and human intervention is minimal.
Include following components:	Include following components:

5.9 Information Technology

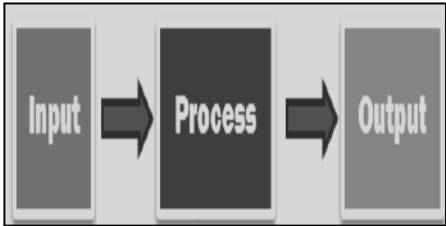
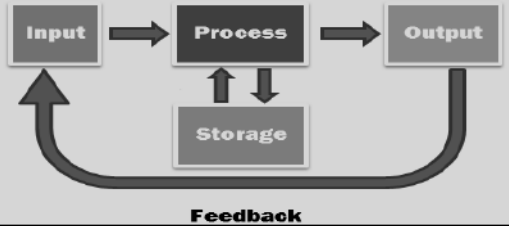
<ul style="list-style-type: none"> ◆ Input: Put details in register. ◆ Process: Summarize the information; and ◆ Output: Present information to management in the form of reports. 	<ul style="list-style-type: none"> ◆ Input: Entering data into the computer; ◆ Process: Performing operations on the data; ◆ Storage: Saving data, programs, or output for future use; and ◆ Output: Presenting the results.
	

Question 3

What are the major control objectives in Business Process Automation (BPA)?

Answer

Control is defined as policies, procedures, practices and organization structure that are designed to provide reasonable assurance that business objectives are achieved and undesired events are prevented or detected and corrected. Major control objectives are given as follows:

- ◆ **Authorization** – ensures that all transactions are approved by responsible personnel in accordance with their specific or general authority before the transaction is recorded.
- ◆ **Completeness** – ensures that no valid transactions have been omitted from the accounting records.
- ◆ **Accuracy** – ensures that all valid transactions are accurate, consistent with the originating transaction data, and information is recorded in a timely manner.
- ◆ **Validity** – ensures that all recorded transactions fairly represent the economic events that actually occurred, are lawful in nature, and have been executed in accordance with management's general authorization.
- ◆ **Physical Safeguards and Security** – ensures that access to physical assets and information systems are controlled and properly restricted to authorized personnel.
- ◆ **Error Handling** – ensures that errors detected at any stage of processing receive prompts corrective actions and are reported to the appropriate level of management.
- ◆ **Segregation of Duties** – ensures that duties are assigned to individuals in a manner that ensures that no one individual can control both the recording function and the procedures relative to processing a transaction.

Question 4

What are the characteristics of Cloud Computing?

Answer

The following is a list of some of the characteristics of a cloud-computing environment:

- ◆ **Elasticity and Scalability:** Cloud computing gives us the ability to expand and reduce resources according to the specific service requirement. For example, we may need a large number of server resources for the duration of a specific task. We can then release these server resources after we complete our task.
- ◆ **Pay-per-Use:** We pay for cloud services only when we use them, either for the short term or for a longer duration.
- ◆ **On-demand:** Because we invoke cloud services only when we need them, they are not permanent parts of the IT infrastructure. With cloud services, there is no need to have dedicated resources waiting to be used, as is the case with internal services.
- ◆ **Resiliency:** The resiliency of a cloud service offering can completely isolate the failure of server and storage resources from cloud users. Work is migrated to a different physical resource in the cloud with or without user awareness and intervention.
- ◆ **Multi Tenancy:** Public cloud service providers often can host the cloud services for multiple users within the same infrastructure. Server and storage isolation may be physical or virtual depending upon the specific user requirements.
- ◆ **Workload Movement:** This characteristic is related to resiliency and cost considerations. Cloud-computing providers can migrate workloads across servers both inside the data center and across data centers (even in a different geographic area).

Question 5

Discuss advantages and disadvantages of Cloud Computing.

Answer

Advantages of Cloud Computing: It is a cost efficient method to use, maintain and upgrade with almost unlimited storage. It provides an easy access to information and is usually competent enough to handle recovery of information. In the cloud, software integration occurs automatically and the entire system can be fully functional in a matter of a few minutes.

Disadvantages of Cloud Computing: This technology is always prone to outages and other technical issues and surrendering all the company's sensitive information to a third-party cloud service provider makes the company vulnerable to external hack attacks and threats.

Question 6

List out different types of delivery channels through which information is delivered to the user.

5.11 Information Technology

Answer

Delivery channels refer to the mode through which information or products are delivered to users. Delivery Channels for Information include the following:

- Intranet: Network within the company/enterprise;
- E-mail: The most widely used delivery channel for information today;
- Internal newsletters and magazines;
- Staff briefings, meetings and other face-to-face communications methods;
- Notice boards in communal areas;
- Manuals, guides and other printed resources;
- Hand-held devices (PDAs, etc.); and
- Social networking sites like Facebook, WhatsApp etc.

Question 7

Briefly explain Grid Computing. What are possible reasons of using grid computing?

Answer

Grid Computing: Grid Computing is a computer network in which each computer's resources are shared with every other computer in the system. In the ideal grid computing system, every resource is shared, turning a computer network into a powerful supercomputer. With the right user interface, accessing a grid computing system is no different than accessing a local machine's resources.

Some of the reasons of using Grid Computing are as follows:

- Civil engineers collaborate to design, execute, & analyze shake table experiments.
- An insurance company mines data from partner hospitals for fraud detection.
- An application service provider offloads excess load to a compute cycle provider.
- An enterprise configures internal & external resources to support e-Business workload.
- Large-scale science and engineering are done through the interaction of people, heterogeneous computing resources, information systems and instruments, all of which are geographically and organizationally dispersed.

Question 8

What are the components of the Computerized Information processing Cycle?

Answer

The components of a Computerized Information Processing Cycle include the following:

- **Input:** Entering data into the computer;

- **Processing:** Performing operations on the data;
- **Storage:** Saving data, programs, or output for future use; and
- **Output:** Presenting the results.

Question 9

What are the major process controls, which should be enforced through front end application system, to have consistency in the control process?

Answer

The Process Controls that should be enforced through the front end application system, to have consistency in the control process are as follows:

- **Run-to-Run Totals:** These help in verifying data that is subject to process through different stages. A specific record can be used to maintain the control total.
- **Reasonableness Verification:** Two or more fields can be compared and cross verified to ensure their correctness.
- **Edit Checks:** Edit checks similar to the data validation controls can also be used at the processing stage to verify accuracy and completeness of data.
- **Field Initialization:** Data overflow can occur, if records are constantly added to a table or if fields are added to a record without initializing it.
- **Exception Reports:** Exception reports are generated to identify errors in data processed.
- **Existence/Recovery Controls:** The check-point/restart logs facility is a short-term backup and recovery control that enables a system to be recovered if failure is temporary and localized.

Question 10

Write short note on the following:

- (a) Network Virtualization
- (b) MS Office Applications
- (c) **Cryptographic Controls**
- (d) **Storage Virtualization**

Answer

- (a) **Network Virtualization:** In Information Technology, Virtualization is the process of creating logical computing resources from available physical resources. This is accomplished using virtualization software to create a layer of abstraction between workloads and the underlying physical hardware. Network Virtualization allows a large physical network to be provisioned into multiple smaller logical networks and conversely allows multiple physical LANs to be

5.13 Information Technology

combined into a larger logical network. This behavior allows administrators to improve network traffic control, enterprise and security.

- (b) **MS Office Applications:** These are various office automation systems made available by Microsoft Corporation which include MS Word, MS Excel, MS PowerPoint, MS Access, etc. Each of these software help to achieve automation of various tasks in the office. It has features such as customized ribbon, backstage view, built-in graphics toolset, enhanced security, excel spark lines, pivot for Excel, PowerPoint broadcast, Power Point compression, paste, preview and outlook conversation view.
- (c) **Cryptographic Controls:** *These controls are exercised in the boundary subsystem and are designed to protect the privacy of data and to prevent unauthorized modifications of data. Cryptography achieves this goal by scrambling data into codes (cryptograms) so that it is meaningless to anyone who does not possess the authentication to access the respective system resource or file. Examples are encryption, digital signature etc.*
- (d) **Storage Virtualization:** *Storage virtualization is the apparent pooling of data from multiple storage devices, even different types of storage devices, into what appears to be a single device that is managed from a central console. Storage virtualization helps the storage administrator perform the tasks of backup, archiving, and recovery more easily - and in less time - by disguising the actual complexity of a Storage Area Network (SAN). Administrators can implement virtualization with software applications or by using hardware and software hybrid appliances. The servers connected to the storage system aren't aware of where the data really is. Storage virtualization is sometimes described as "abstracting the logical storage from the physical storage".*

Question 11

Define 'On-line processing' and 'Real-time processing'.

Answer

Online Processing: In this, data is processed immediately while it is entered, the user usually only has to wait a short time for a response. (Example: games, word processing, booking systems). Interactive or online processing requires a user to supply an input. Interactive or online processing enables the user to input data and get the results of the processing of that data immediately.

Real-time Processing: Real time processing is a subset of interactive or online processing. Input is continuously, automatically acquired from sensors which are processed immediately in order to respond to the input in as little time as possible. The system doesn't need a user to control it. Real time processing is used in warning systems on aircraft, alarm systems in hazardous zones, burglar alarms etc.

Question 12

Describe the Information Systems Management Control usually performed by the Top Management.

Answer

Top Management and Information Systems Management Controls: Top management must ensure that information systems function is well managed. It is responsible primarily for long – run policy decisions on how Information Systems will be used in the organization. Information Systems management has overall responsibility for the planning and control of all information system activities.

It also provides advice to top management in relation to long-run policy decision making and translates long-run policies into short-run goals and objectives. The senior managers who take responsibility for Information System function in an organization face many challenges. The major functions that a top/senior manager must perform are as follows:

- **Planning – determining the goals of the information systems function and the means of achieving these goals;**
- **Organizing – gathering, allocating, and coordinating the resources needed to accomplish the goals;**
- **Leading – motivating, guiding, and communicating with personnel; and**
- **Controlling – comparing actual performance with planned performance as a basis for taking any corrective actions that are needed.**

Top management must prepare two types of information systems plans for the information systems function: Strategic Plan and an Operational Plan. The Strategic Plan is the long-run plan covering, say, the next three to five years of operations whereas the Operational Plan is the short-plan covering, say, next one to three years of operations.

Question 13

Discuss the constraints that need to be taken into consideration while developing a secured Grid Architecture.

Answer

To develop a secured Grid architecture, following constraints are needed to be taken into consideration:

- **Single Sign-on: A user should authenticate once and they should be able to acquire resources, use them, and release them and to communicate internally without any further authentication.**
- **Protection of Credentials: User passwords, private keys etc. should be protected.**

- **Interoperability with local security solutions:** Access to local resources should have local security policy at a local level. Despite of modifying every local resource there is an inter-domain security server for providing security to local resource.
- **Exportability:** The code should be exportable i.e. they cannot use a large amount of encryption at a time. There should be a minimum communication at a time.
- **Support for secure group communication:** In a communication, there are number of processes which coordinate their activities. This coordination must be secure and for this there is no such security policy.
- **Support for multiple implementations:** There should be a security policy which should provide security to multiple sources based on public and private key cryptography.

Question 14

Discuss the constraints that need to be taken into consideration while developing a secured Grid Architecture.

Answer

To develop a secured Grid architecture, following constraints are needed to be taken into consideration:

- **Single Sign-on:** A user should authenticate once and they should be able to acquire resources, use them, and release them and to communicate internally without any further authentication.
- **Protection of Credentials:** User passwords, private keys etc. should be protected.
- **Interoperability with local security solutions:** Access to local resources should have local security policy at a local level. Despite of modifying every local resource there is an inter-domain security server for providing security to local resource.
- **Exportability:** The code should be exportable i.e. they cannot use a large amount of encryption at a time. There should be a minimum communication at a time.
- **Support for secure group communication:** In a communication, there are number of processes which coordinate their activities. This coordination must be secure and for this there is no such security policy.
- **Support for multiple implementations:** There should be a security policy which should provide security to multiple sources based on public and private key cryptography.

Question 15

Explain the concept of Virtualization. Enumerate major applications of Virtualization.

Answer

Virtualization: In computing, Virtualization means to create a virtual version of a device or resource, such as a server, storage device, network or even an operating system where

the framework divides the resource into one or more execution environments. Virtualization refers to technologies designed to provide a layer of abstraction between computer hardware systems and the software running on them. The core concept of Virtualization lies in Partitioning, which divides a single physical server into multiple logical servers. Once the physical server is divided, each logical server can run an operating system and applications independently.

Major applications of the concepts of the virtualization are as follows:

- **Server Consolidation:** *Virtual machines are used to consolidate many physical servers into fewer servers, which in turn host virtual machines. Each physical server is reflected as a virtual machine "guest" residing on a virtual machine host system. This is also known as "Physical-to-Virtual" or 'P2V' transformation.*
- **Disaster Recovery:** *Virtual machines can be used as "hot standby" environments for physical production servers, i.e. changes "backup-and-restore" philosophy, by providing backup images that can "boot" into live virtual machines, capable of taking over workload for a production server experiencing an outage.*
- **Testing and Training:** *Virtualization can give root access to a virtual machine. This can be useful in kernel development and operating system courses.*
- **Portable Applications:** *Portable applications are needed when running an application from a removable drive, without installing it on the system's main disk drive. Virtualization can be used to encapsulate the application with a redirection layer that stores temporary files, windows registry entries and other state information in the application's installation directory and not within the system's permanent file system.*
- **Portable Workspaces:** *Recent technologies have used virtualization to create portable workspaces on devices like iPods and USB memory sticks.*

Exercise

1. *Discuss some of the applications that help enterprise to achieve Business Process Automation.*
2. *How can controls be classified based on the time at which they are applied?*
3. *Discuss the steps involved in implementing Business Process Automation.*
4. *Define the following terms in brief.*
 - (a) *Cloud Computing*
 - (b) *Grid Computing*
 - (c) *Control in BPA*

5.17 Information Technology

5. *Discuss the major parameters that need to be considered while choosing an appropriate delivery channel for information.*
6. *Discuss Boundary Controls and Communication controls in detail.*
7. *What do you understand by Database Controls under Application Controls? Discuss in brief.*
8. *Differentiate between Input Controls and Output Controls.*
9. *Differentiate between Systems Development Management Controls and Programming Management Controls under Managerial Functions Based controls.*